

SOLID-STATE SENSING

A Professional Course

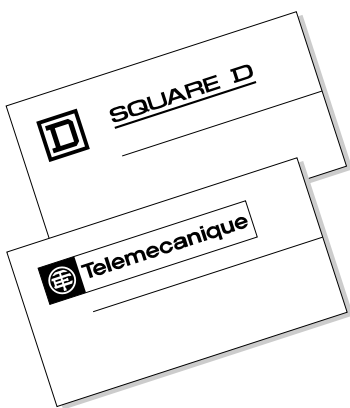
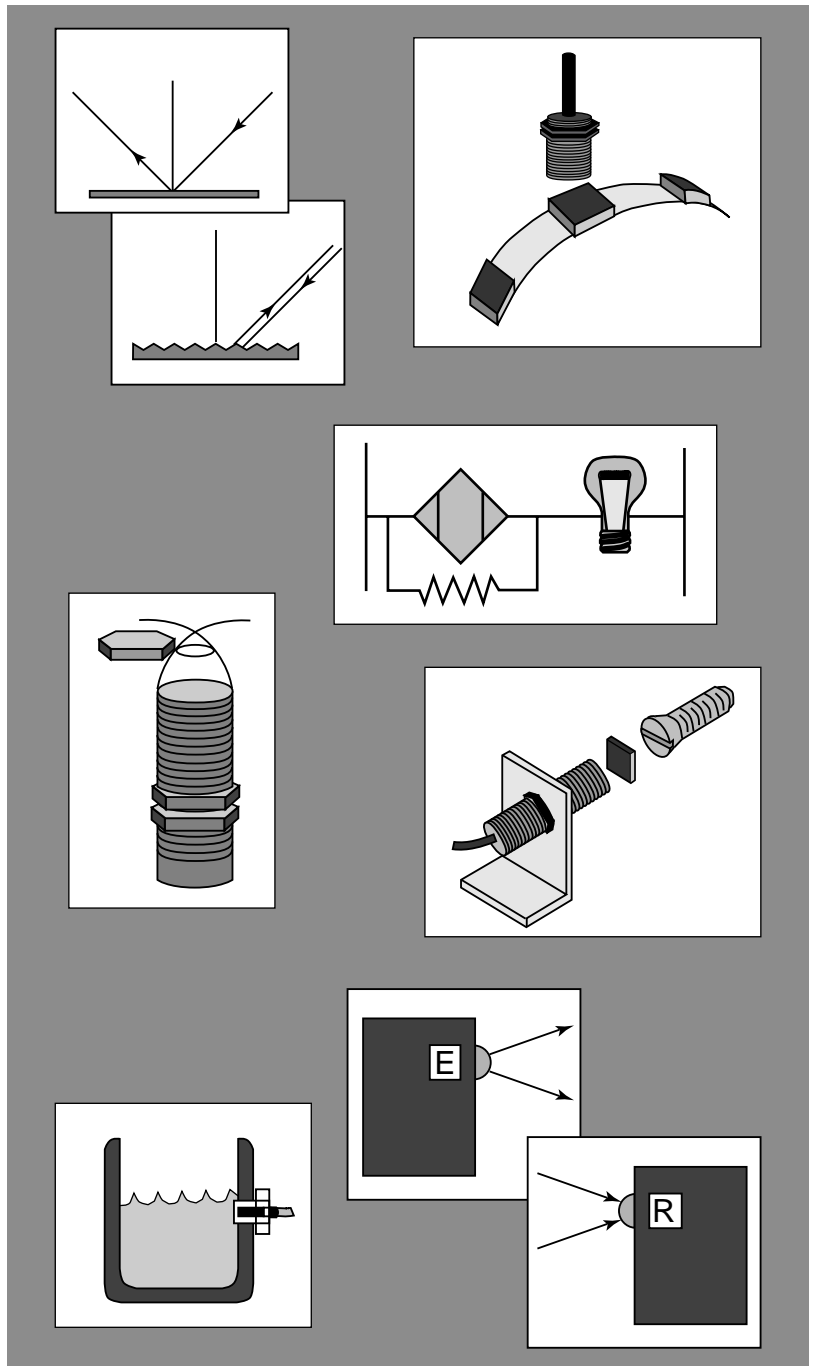

CONTENTS

CHAPTER		PAGE
1	INTRODUCTION TO SENSING TECHNOLOGIES An overview of the sensing technologies at work in industry today, covering the basic mechanics of how each technology functions.	1
2	SENSOR TYPES Discusses sensor types, including reed relay, inductive, capacitive, photoelectric, and fiber-optic.	6
3	INDUCTIVE SENSORS Presents the physics of inductive sensing and a variety of applications.	14
4	OUTPUT THEORY Discusses electronic versus electromechanical sensor output, including TRIACs, transistors, and 2- and 3-wire technology.	21
5	INTERFACING SENSORS WITH LOADS Presents methods of interfacing sensors with resistive and inductive loads. Topics include wiring PLC input modules, AC and DC inductive loads, wiring in series and in parallel, short-circuit protection, and DC power supplies.	25
6	TARGET SPEED AND RESPONSE TIME Provides information on response time with respect to power-up delay, on delay, off delay, and observable time. Three case studies present the methods used to calculate observable time.	32
7	STANDARD OPERATING FREQUENCY Provides information on operating frequency and its importance as a sensor selection criterion. Contains an overview of timing functions and how they are applied in various sensing situations.	40

CHAPTER 1

Introduction to Sensing Technologies

Basically, a sensor is any of various devices designed to detect, measure or record physical phenomena — such as radiation, heat, pressure, or presence — and to respond by transmitting information, initiating changes, or operating controls (Figure 1).

PRESENCE DETECTION

Presence sensors detect the presence of an object — a target material. In industry, there are as many targets as there are products and components of products. As you will see, there are many problems unique to certain targets, but there are different sensing technologies which can be applied to solve the problem.

In the context of an automated manufacturing process, sensors are essential in providing positioning data so controllers, such as PLCs, can perform their tasks all along the production line. In the context of safety, sensors in safety interlock doors and guards keep operators safely guarded from hazardous processes. They also aid manual processes, such as positioning of fork lifts for material handling and trucks in shipping docks. They are used in counting and rotary speed monitoring. In any automated material handling application, sensors close the data loop between the operator, the controller, and the process. There are 2 general types of sensing:

1. Discrete (on-off)
2. Analog (continuous-proportional)

Analog gives a continuous response, answering the question, “Where is it?” Analog responds best to continuous processes, such as level control, positioning, etc.

The discrete type answers the question, “Is it here, or not?” Discrete sensors have a contact, and the ON-OFF position corresponds to the discrete states. The discrete type is most applicable to manufacturing, since most sensing applications deal with processes which demand that a target be in a definite position for assembly, or at a specific level for filling. In situations such as materials handling or the assembly of products, manufacturing systems need to know when the target is at a given location. They don’t need to know when the target is almost there, or almost gone.

There are 2 general categories of presence sensors (Figure 2):

1. Physical contact (example: limit switch)
2. Noncontact (example: photoelectric sensor)

As an example, you would want a noncontact sensor to detect the presence of freshly painted car doors as a means of counting how many had been sent on to the curing area.

NONCONTACT SENSORS VERSUS LIMIT SWITCHES

With limit switches, the target directly actuates the switch through physical contact. Noncontact sensors are, with few exceptions, solid-state electronic devices which offer the following advantages:

- Physical contact is not required.
- No moving parts to jam, fail, or be broken by extreme physical contact.
- Faster.
- No bouncing at contact state change.

Advantages of limit switches include:

- Carry more current.
- Are safer—when opened, there is an air gap between the contact terminals.

COMPONENTS OF A SOLID-STATE SENSOR

In generic terms, solid-state sensors will have an interface, generally an oscillating circuit, the kind of which is the main distinction between the technologies (Figure 3). The inter-

face translates the distance into an electrical signal. A trigger, or threshold level detector, is used to trigger the output circuit when the signal reaches a predetermined level. An output circuit interfaces with data acquisition systems (PLCs, dedicated controllers), or other control circuits (relays, counters, timers, etc.).

DISCRETE SENSING IN THE REAL WORLD

The wavy line in Figure 4 expresses the real variation of the distance between the target and sensor. The line is wavy because we are dealing with nonuniform movement caused by vibration or jerkiness in the mechanical systems which are found in a real industrial environment. The variations can be a problem, especially in slow-moving applications. With only a single threshold, those small changes in distance cause a chattering effect between the ON and OFF states. This is noise that we need to eliminate.

If we introduce a second threshold for OFF above the threshold for ON, the small waveforms between the two are filtered-out and the chattering is suppressed. The distance between the ON and OFF thresholds is the differential.

Differential, also called hysteresis, is the distance between the operating point and the

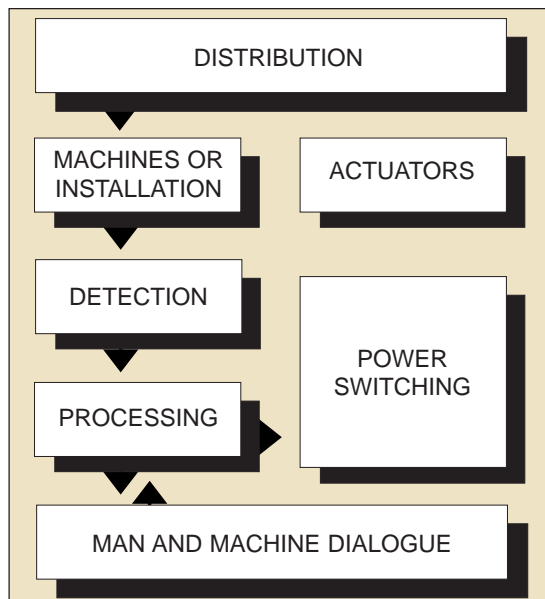

FIGURE 1. Components and systems for automation.

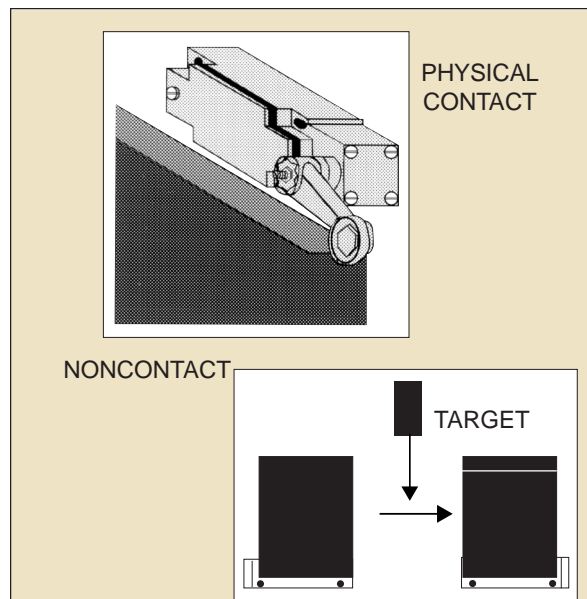

FIGURE 2. The 2 general categories of presence sensors.

release point as the target is moving away. Differential is necessary in order to make a precise determination of target presence without factors of the environment intervening to create a noisy output signal. All discrete sensing technologies must have a differential. In some technologies, differential occurs as a by-product of the basic laws of physics. However, in other technologies it must be manufactured through additional circuitry.

MAJOR NONCONTACT SENSING TECHNOLOGIES

The major noncontact sensing technologies are:

- Reed Relay (Magnetic Target)
- Inductive (Metal Target)
- Capacitive (All Materials Target)
- Photoelectric (All Materials Target)

Inductive, capacitive and photoelectric technologies compose the majority of industry's applications, but other technologies are in the field and you should be aware of them. They are:

- Ultrasonic (All Materials Target)
- Magnetic Reluctance (Magnetic Metals Only)
- Hall Effect (Magnetic Target)

Generally, the more control you have over what passes in front of the sensor, the better. The less control you have over what passes in

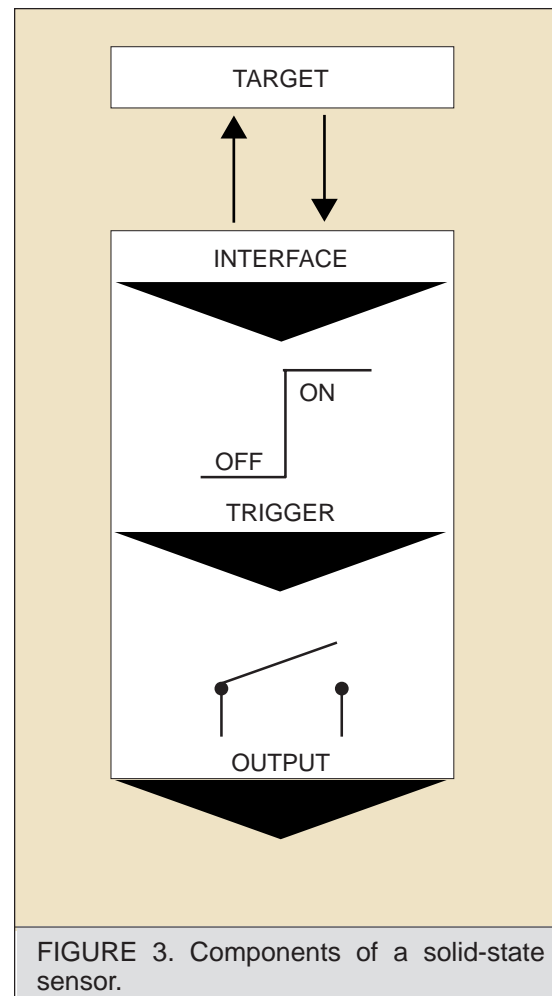

FIGURE 3. Components of a solid-state sensor.

TABLE 1 — TERMINOLOGY

Nominal sensing distance: The rated operating distance for which the switch is designed. This value should only be taken as a guide, since no manufacturing tolerances or changes in external operating environment are taken into account. You should be aware that manufacturers arrive at performance standards for their products using standardized criteria, so you can compare “apples to apples” in determining which product is right for your application. These criteria reflect, to a reasonable extent, the real performance which can be expected in an “average” controlled environment.

Usable sensing distance: This sensing distance is used for specifying a specific sensor for an application. Relative to a standard target, the usable sensing distance takes manufacturing tolerances and external operating conditions into account. This specification gives confidence to the specifier — all devices are guaranteed by the manufacturer to perform within the usable sensing distance.

Effective (or Real) sensing distance: This is the actual sensing distance realized by the actual application. The effective sensing distance will be no less than the usable, and is usually closer to the nominal in average circumstances.

Standard target: An object with standardized dimensions or characteristics—common among manufacturers—used in the product laboratory to determine benchmark performance characteristics for a sensor (Figure 5).

Target: The *real* object to be sensed.

TABLE 2 — NEMA ENCLOSURE RATINGS (AMERICAN)

Classifications

- 1** For indoor use — protection against contact with enclosed equipment.
- 3** For outdoor use — windblown dust, rain, sleet, external ice formation.
- 4** Windblown dust, rain, hose directed water.
- 4x** Corrosion, splashing, hose directed water.
- 6** Short-term immersion in water, limited depth.
- 6p** Long-term immersion (8 hours at 6 ft. depth).
- 6x** Saline mist, withstanding UV.
- 11** Oil immersion, corrosive liquids and gases.
- 12** For indoor use — dust, falling dirt, dripping non-corrosive liquids.
- 13** For indoor use — lint, dust, seepage, external condensation and spraying of water, oil and non-corrosive liquids.

front of the sensor, the more selective the sensor must be for identifying the target. Reed relay is among the best in this regard because it senses only magnetic targets, and magnets are rare in industry. If you differentiate your target by putting a magnet on it and use a reed relay to detect its presence, it won't be fooled by other objects that don't have magnets attached.

Inductive sensors detect metal and would not be fooled by non-metal objects. This is a highly accurate technology, so if you are able to control what metal objects pass in front of the

sensor, this technology is good at letting you know precisely when they are within sensing (detection) range. Photoelectric can be fooled very easily — if you break the beam, something is sensed. That object could be the target, operator's hand, or nothing but a cloud of dust!

REPEATABILITY

Repeatability is the ability of a specific sensor to repeatedly detect a target at a given point. It is related to the precision needed for the application. For example, are you filling a bottle that requires a positioning

TABLE 3 — IEC ENCLOSURE RATINGS (EUROPEAN)

1st Characteristic numeral

Protection against contact and penetration of solid bodies.
Conforming to IEC, NFC, DIN.

- 0** Non-protected.
- 1** Protection against solid objects greater than 50mm.
- 2** Protection against solid objects greater than 12mm.
- 3** Protection against solid objects greater than 2.5mm.
- 4** Protection against solid objects greater than 1mm.
- 5** Dust protected.
- 6** Dust tight.

2nd Characteristic numeral

Protection against contact and penetration of liquids.
Conforming to IEC, NFC, DIN.

- 0** Non-protected.
- 1** Protection against dripping water.
- 2** Protection against dripping water when tilted up to 15°.
- 3** Protection against rain.
- 4** Protection against splashing water.
- 5** Protection against water jets.
- 6** Protection against heavy seas.
- 7** Protection against the effects of immersion (short term).
- 8** Protection against immersion in cutting oils. (Telemecanique/Square D proposal)

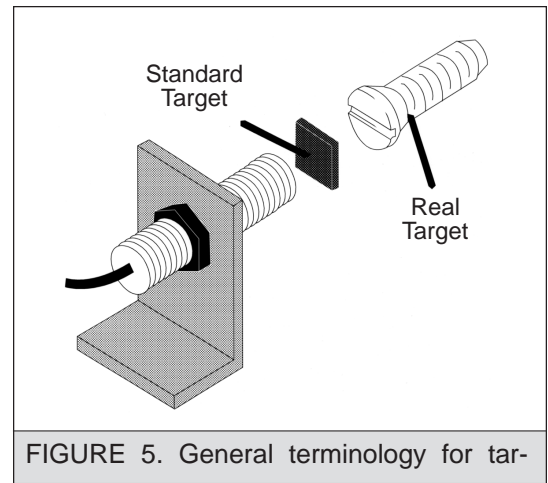
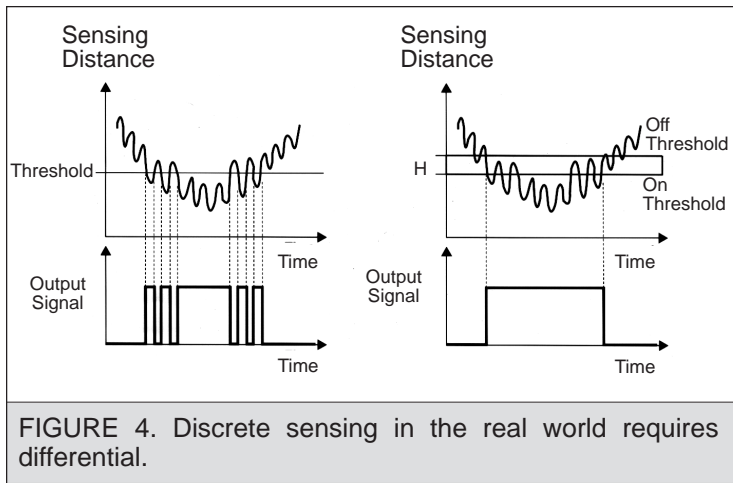

accuracy of $\pm 1/16$ of an inch at the filling station, otherwise you have product spilling on the floor? Or are you interested in sensing the presence of a car in an automatic car wash with an accuracy of ± 1 foot?

RATING THE TECHNOLOGIES FOR REPEATABILITY

Different technologies offer varying levels of precision. Rating the technologies for repeatability in descending order:

1. Limit Switches
2. Reed Relay (magnetic target)
3. Inductive
4. Photoelectric
5. Capacitive

ENCLOSURE RATINGS

An enclosure is a surrounding case constructed to provide protection to personnel against incidental contact with the enclosed equipment, and also to protect the equipment from environmental conditions: water splashing, short-time immersion, cutting oils, and saline mist. The American standards for enclosures are provided by NEMA, and the European standards are provided by IEC. The most important NEMA classifications are listed in Table 2.

The IEC system has IP ratings (Table 3); 2 digits are normally used. The first digit describes the dimensions of the solid object that can penetrate the enclosure. Maximum protection is 6, which is dustproof. The second digit represents the enclosure's ability to withstand liquids, with 7 as the maximum, representing short-term immersion in water, similar to

NEMA 6. Therefore, an IP67 is an excellent rating common to most sensors.

The IEC standard allows an even higher letter grade: IP68. The 8 for liquids is not defined by IEC, rather, it is left to the users and manufacturers to define for specialized circumstances. □

CHAPTER 2

Sensor Types

REED RELAY: FOR MAGNETIC TARGETS ONLY

Reed proximity switches are actuated by the presence of a magnetic field caused by a permanent or electromagnet. Typical sensing range is 0 to 1.5".

The sensor is called a reed relay because it has two little ferromagnetic reeds hermetically sealed in a glass bulb such that they overlap, but don't touch. When a magnet is brought close to the reed bulb, the foil reeds take on opposite magnetic properties and attract each other. The reeds make contact, closing the circuit.

Referring to Figure 1, when the north end of a magnetic field is introduced to the reed head-on, the relay actuates in the area shown by the solid line. This distance will vary according to the strength of the magnet. As the magnet is removed from the area, the reed relay opens at the dotted line. The difference between the point of actuation as the magnetic target comes closer and the point of de-actuation as the target moves away is the *differential*. This is a naturally occurring phenomenon when using this technology. Note that when the magnet approaches the reed in a plane perpendicular to the reed's axis, the area of commutation is altered, and 2 areas of actuation are created. This is not desired because it gives 2 signals for one target pass.

MAGNETICALLY-ACTUATED SWITCH APPLICATIONS

The more selective your sensor can be for the target, the better, and the more control you have over what passes in front of the sensor, the better. Reed relay is among the best in this regard because it senses only magnetic targets, and magnets are rare in industry. Applications, advantages and disadvantages of magnetically actuated switches follow.

Applications:

- Security and safety — when non-target material can accidentally trip other detectors. Ideal for security applications, since magnets are not very common materials. Because reed relay is a noncontact sensing technology, breakdown from mechanical wear is virtually eliminated. Examples: Security door interlock; secondary switches for operator safety applications (redundant system for safety, in addition to a switch with a direct opening action contact).
- Sensing through metal walls (non-ferrous). Example: Piston position in an air or hydraulic cylinder (the piston has a magnetic band).
- Identification of metal bins, containers. Example: Magnetic tape or small magnets in preassigned slots can uniquely identify a carrier on an automatic assembly line.

- Environments where sand, dirt, dust, oil or coolants are prevalent.
- Ideal for high-speed operation.

Advantages:

- No bouncing. Great for interfacing with PLCs or other solid-state circuits.
- Excellent low-current characteristics.
- A low-cost alternative to other proximity sensing technologies.

Disadvantages:

- Welds easily, causing failure. As a precaution, use a resistor in series to limit current surges for long cable runs.
- Sensitivity to welding fields; do not use in close proximity.
- Needs magnet.

INDUCTIVE PRINCIPLES

An inductive detector senses the proximity of a metal object utilizing an oscillator principle. Surface currents, known as eddy currents, are induced in the metal target by the electromagnetic oscillating field. These target currents react with the oscillator's field — the closer the target, the stronger the reaction.

When the metal target is outside the oscillator influence, the magnitude of the oscillations is not impeded. When the target is inside the field, it attenuates the magnitude, eventually stopping the oscillator. That's why it's named ECKO (Eddy Current Killed Oscillator).

Figure 2 shows how the proximity of a metal target affects the magnitude of oscillations, and therefore the output voltage.

SELECTING INDUCTIVE SENSORS

The usable sensing distance and repeatability are some of the most important attributes in matching sensor technology to real-world applications. Nominal sensing distances range from 0" to 2". Choose tubular or rectangular sensors based on the mounting requirements of the application. Tubular sensors install in holes, while rectangular sensors mount to flat surfaces (Figure 3). Tubular devices allow for sensing distance adjustment when mounting, while

the rectangular do not.

SHIELDED AND NONSHIELDED INDUCTIVE SENSORS

The nonshielded sensor has a field which extends around the front surface to the sides of the unit (Figure 4). When a metal target enters this field, there is a predictable point at which the unit will sense its presence. The field must be loaded with metal to a threshold point, and then the sensor will change states. When the target is closer to the sensor, less metal has to be introduced to the field to make the sensor change states. Using a standard target, a predictable curve can be plotted to define the sensing distance characteristics.

If a nonshielded inductive sensor is mounted in metal such that the metal is in the field (embedded), this will "pre-load" the field and the sensing pattern will no longer be predictable.

The shielded sensor introduces metal into the field within the switch itself. Metal mounting brackets or fixtures will not influence the sensing pattern. The shielded sensor can even be flush-mounted in metal. Note that a shielded sensor of a given type will have a shorter sensing distance than its nonshielded counterpart. On the other hand, it will be better protected mechanically.

CAPACITIVE PRINCIPLES

This is an "all materials" type of sensor. Capacitive proximity switches contain a high-frequency oscillator with one or both of its capacitor plates built into the end of the sensor. Typical sensing ranges are from 0 to 3/4 of an inch. When the target is outside the oscillator field, there is a weak capacitive coupling. When the target is within the oscillating field, a strong capacitive coupling develops. The sensing zone is influenced by the physical properties of the medium being sensed. All materials in the sensor's proximity are sensed by the change in dielectric characteristics versus air.

Capacitive proximity switches lend themselves to applications requiring the sensing of bulk and liquid level, and nonmetallic objects such as glass and plastic. It is the last choice for detecting metal targets because of

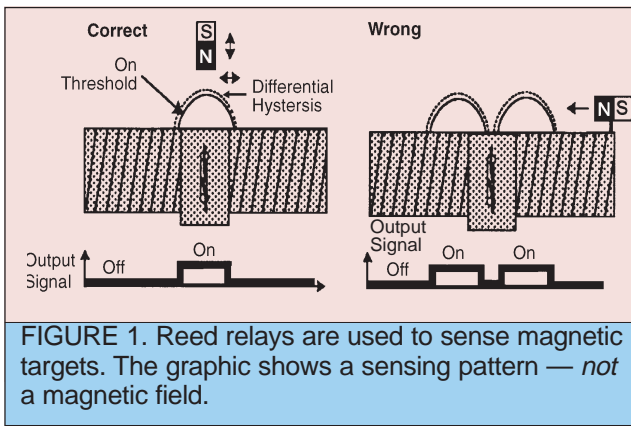

its non-selectivity (relative to inductive technology).

A typical installation is in the side of a nonmetallic vat (Figure 5). The capacitive sensor can detect the level of the liquid or dry material right through the wall, without coming into contact with it.

Weaknesses of capacitive sensors include:

- The actual sensing range of the switch varies widely according to the medium being sensed.
- Very sensitive to environmental factors.
- Not selective for its target — easily fooled. Control of what comes close to the sensor is essential.
- If tank is grounded or too thick, will need a special “well bracket.”

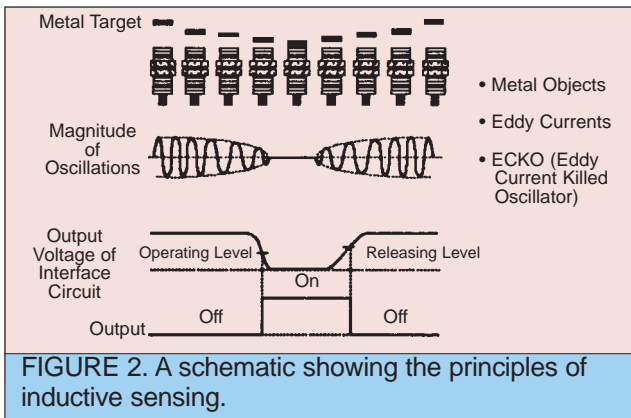

PHOTOELECTRIC SENSING

The principles of light emission and reception are used to sense the target. Figure 6 shows the emitter and receiver. The emitter is a device that emits a beam of light (usually infrared) when an electric current is applied. The receiver is a device that changes its output state when light from the emitter is received. There are three basic configurations for photoelectric sensing (Figure 7):

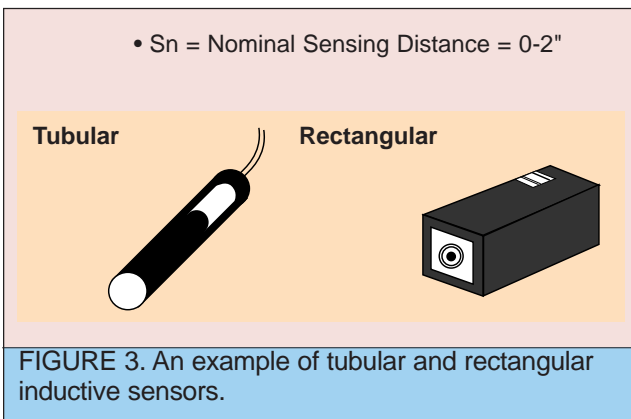

1. Thru-beam, where the target passes between an emitting unit and receiving unit, blocking the beam. These are separate, powered units.

2. Retroreflective, where the target passes between the sensor and a reflector. The emitter and receiver are in the same housing. The reflector establishes the beam between emitter and receiver.

3. Proximity (diffuse), where the unit senses the light directly from the target. The emitter and receiver are in the same housing, the same as retroreflective, but the receiver is more sensitive to the weaker light which is diffused by the surface of the target.

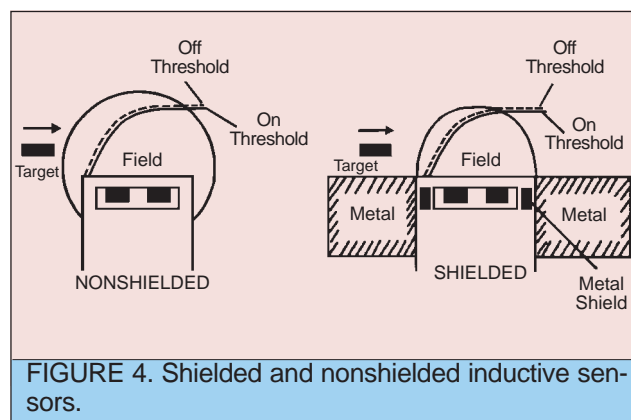

The types and use of photoelectrics are increasing at a rapid rate because they are extremely versatile. They can be used to detect the presence or absence of nearly any material or object without contacting it physically, and can function at a consider-

able distance from the target. Photoelectronics are reliable and have rapid response times because they employ a solid-state design and no-touch actuation. This results in long, low-cost operation.

GENERAL PHOTOELECTRIC TERMINOLOGIES

Retroreflector: A corner cube reflector does something that a mirror cannot do — it reflects energy back to the source from which it came when the source is not in a perpendicular direction (Figure 8). That's why similar kinds of reflectors are used on cars and road signs to provide a passively lighted warning at night.

Compare the diagrams (Figure 8) and notice how mirrors differ from reflectors. The mirror reflects light such that the angle of reflection is equal to the angle of incidence. The reflector sends light back parallel to the rays of incidence.

You might wonder if a mirror could be used with an angle of incidence of 90° , but you would find this only workable in the laboratory, and only then after much careful alignment. A good reflector sends light back to the sensor even at a 45° angle. The corner cube reflector makes retroreflective photoelectric sensing practical.

Reflectors are available in different sizes and forms to do different jobs. For special situations, there are reflective tapes.

Sensing Range: With respect to the three basic modes of photoelectric scanning, *sensing range* is the distance between an emitter and a receiver, an emitter and reflector, or emitter and an object in the path of the beam within which nominal operation is achievable. Note that this does not take into account environmental factors or variations in the nature of the target.

When relating sensing distance to photoelectric proximity sensors, certain reference standards for reflectivity are used, such as 90% white Kodak paper for the standard target. A 3" reflector is used for retroreflective sensing mode.

Usable Sensing Distance: Taking the actual operating conditions into account, the usable sensing distance is the maximum reliable operating range for a given system.

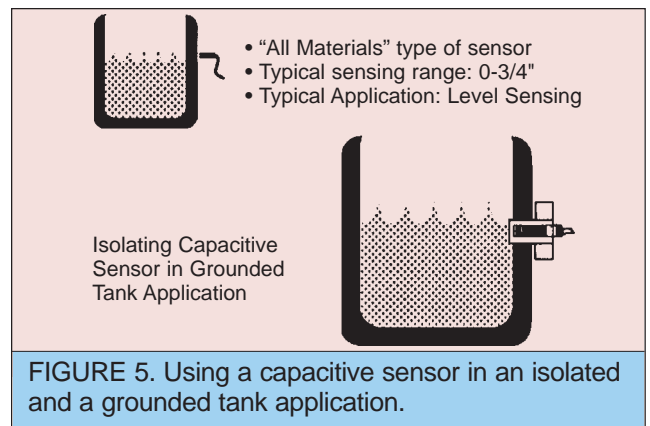

FIGURE 5. Using a capacitive sensor in an isolated and a grounded tank application.

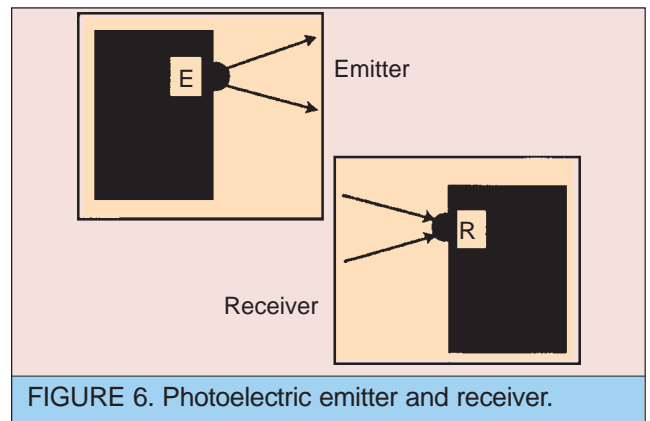

FIGURE 6. Photoelectric emitter and receiver.

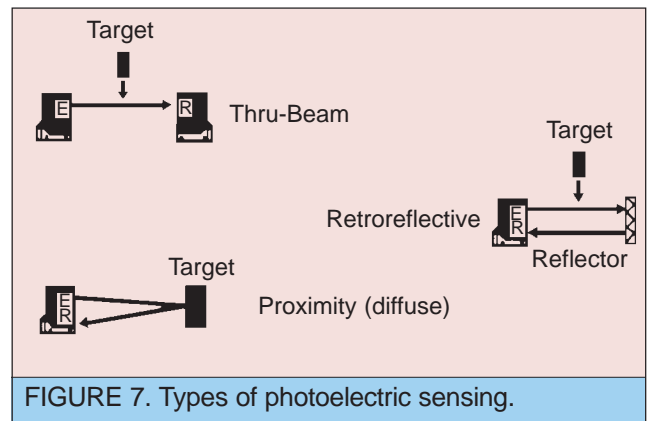

FIGURE 7. Types of photoelectric sensing.

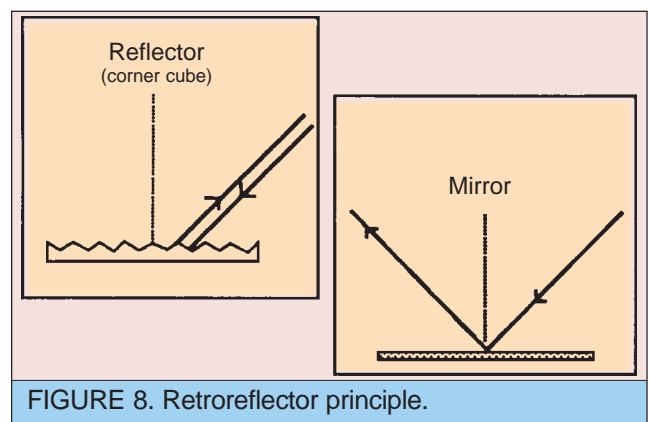
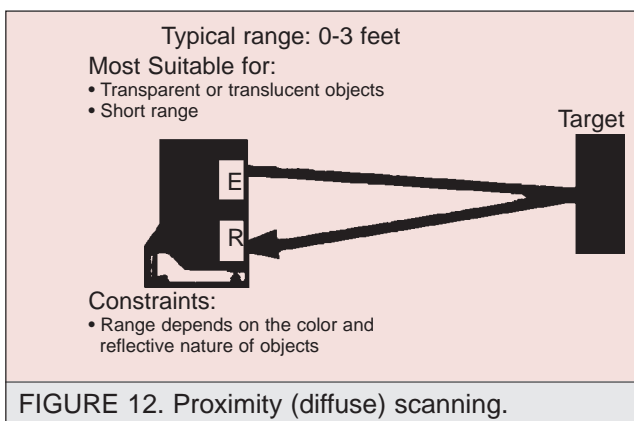
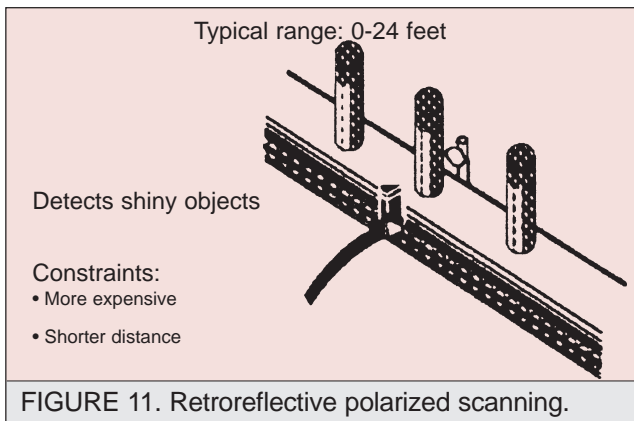
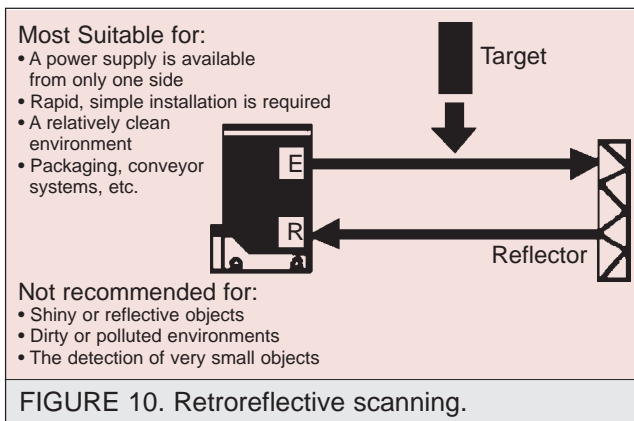
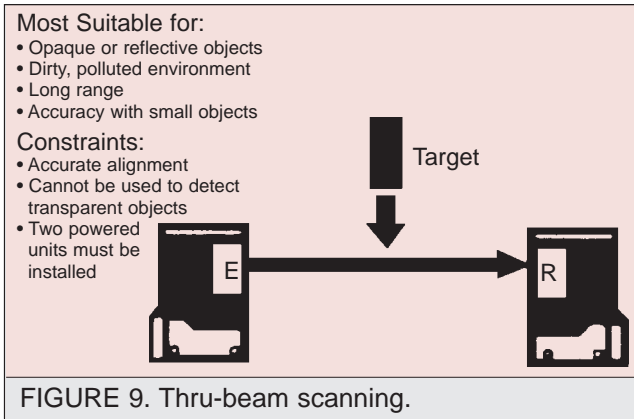

FIGURE 8. Retroreflector principle.



The most important factors to consider are atmospheric environment and the reflective nature of the target.

Repeatability: Unlike inductive sensors, which have repeatability that can be expressed as a percentage of their usable sensing distances, photoelectrics have indefinable repeatability because there are so many external factors that can affect their performance. The precision of photoelectric sensing resolution is dependent on not only the size of the beam and the size of the target, but also where the target is within the sensing range, the humidity, and the amount of dust in the area.

THRU-BEAM SCANNING

In thru-beam scanning, the emitter and receiver are in separate enclosures (Figure 9). Of the photoelectric scanning types, thru-beam is the most predictable, with typical ranges from 0 to 200 feet.

The system is most suitable for:

- The detection of opaque or reflective objects.
- Use within a dirty, polluted environment (dust, rain, mist). At shorter distances than the nominal one, the excess power helps “burn through” pollutants.
- Applications requiring long-range detection.
- Applications where accuracy is important, where small objects are being detected, and for counting systems.

The constraints of thru-beam scanning include:

- Accurate alignment in setup is essential.
- The target should be larger than the beam.
- Cannot be used to detect transparent objects.
- Two powered units must be installed, so this route is more costly and requires more wiring to install.

RETROREFLECTIVE SCANNING

In retroreflective scanning, transmitter and receiver are contained within the same enclosure (Figure 10); the beam is closed by a reflector. Typical ranges are from 0 to 30 feet.

This system is the most suitable for:

- Applications where a power supply is available from only one side of the target.

- Applications where rapid, simple installation is required. The reflector may be mounted at an angle of up to $\pm 15^\circ$ from the line perpendicular to the light beam.
- A relatively clean environment.

It is the most common system used on packaging equipment, conveyors, etc.

This system is not recommended for:

- Applications where shiny or reflective objects are to be detected.
- Very dirty or polluted environments.
- The detection of very small objects. Usually, the target should be larger than the reflector, and very small reflectors are impractical.

RETROREFLECTIVE POLARIZED SCANNING

A polarized photosensor is actually a special retroreflex system which can detect, in addition to normal opaque objects, the shiny objects that fool a normal reflex sensor — mirrors, metal straps, foils, metal boxes, cans, shrink wrap, and mylar tape (Figure 11). Typical ranges are from 0 to 24 feet.

This type of sensor is used extensively by the canning industry to sense aluminum cans and bottles.

Constraints of this technology include:

- More expensive than standard retroreflective.
- Shorter sensing distance.

PROXIMITY (DIFFUSE) SCANNING

In proximity (diffuse) scanning, the transmitter and receiver are contained within the same enclosure (Figure 12). Detection is based on light from the emitter being diffused from a target back to the receiver. Typical ranges are from 0 to 3 feet.

Diffused light is scattered light. We are able to see objects because when light strikes them, the light scatters. Our receivers, our eyes, really don't see the objects themselves, but rather, we see the light diffused by the objects. Diffused light generates a very small signal, compared with retroreflective sensing. That's why we need very sensitive amplifiers to deal with the weaker signal.

This system is most suitable for:

- The detection of transparent or translucent objects such as empty bottles on a conveyor.
- Short range applications.
- Detection of small objects.

Constraints include:

- Usable range depends largely on the color and reflective nature of objects to be detected. Extremely vulnerable to environmental factors such as dust and humidity.
- The area behind the target should be clear of reflective surfaces.

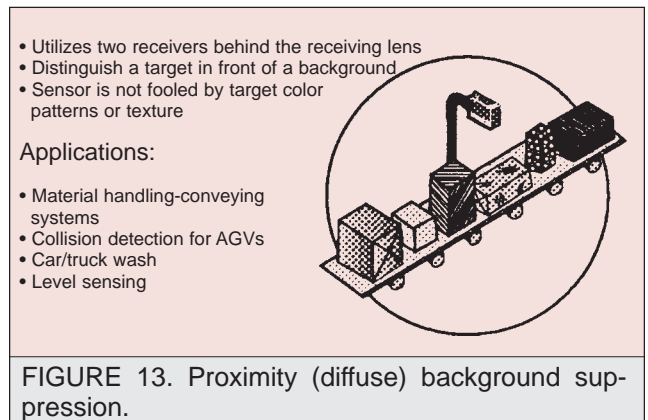

FIGURE 13. Proximity (diffuse) background suppression.

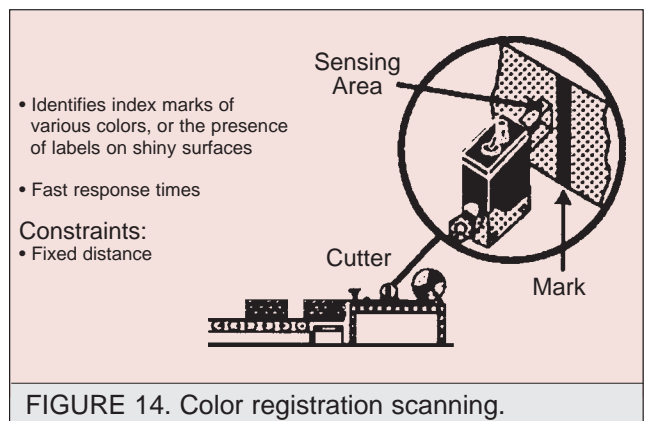

FIGURE 14. Color registration scanning.

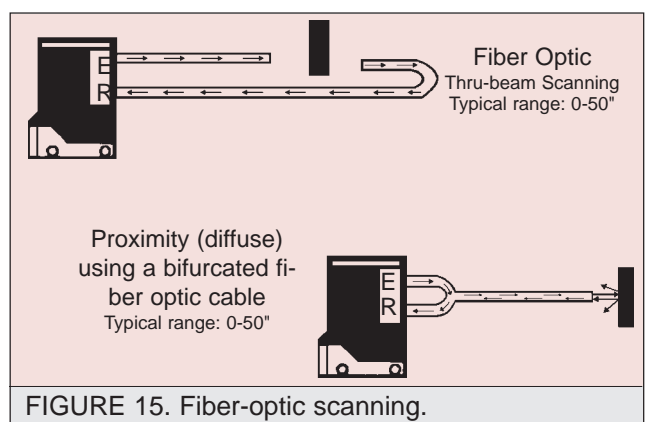

FIGURE 15. Fiber-optic scanning.

Solid-State Sensor Technologies			
	Advantage	Disadvantages	Applications
Magnet Operated (reed relay)	<ul style="list-style-type: none"> ■ Inexpensive; very selective target identification. 	<ul style="list-style-type: none"> ■ Magnet required. ■ Sensitive to welding fields. 	<ul style="list-style-type: none"> ■ Security and safety interlocking. ■ Sensing through metal.
Hall Effect	<ul style="list-style-type: none"> ■ Complete switching function is in a single integrated circuit. ■ Operates up to 150 kHz. ■ High temperature (150 °C). ■ Good resolution. 	<ul style="list-style-type: none"> ■ Magnetic target only. ■ Extremely sensitive to industrial environment. 	<ul style="list-style-type: none"> ■ Keyboard.
Ultrasonic	<ul style="list-style-type: none"> ■ Senses all materials. 	<ul style="list-style-type: none"> ■ Resolution. ■ Repeatability; sensitive to background and environment changes. 	<ul style="list-style-type: none"> ■ Anti-collision on AGV (Automated Guided Vehicles). ■ Doors.
Inductive	<ul style="list-style-type: none"> ■ Resistant to harsh environments. ■ Easy to install; very predictable. 	<ul style="list-style-type: none"> ■ Distance limitation to 60 mm. 	<ul style="list-style-type: none"> ■ Presence detection on all kinds of machines and installations.
Capacitive	<ul style="list-style-type: none"> ■ Senses all materials. ■ Detects through walls. 	<ul style="list-style-type: none"> ■ Very sensitive to environment changes. 	<ul style="list-style-type: none"> ■ Level sensing with liquids and non-metallic parts.
Photoelectric	<ul style="list-style-type: none"> ■ Senses all materials. ■ Longest sensing range. ■ Versatile. 	<ul style="list-style-type: none"> ■ Subject to contamination. 	<ul style="list-style-type: none"> ■ Parts detection. ■ Material handling. ■ Packaging.

- Their use is not recommended for dirty environments.

PROXIMITY (DIFFUSE) BACKGROUND SUPPRESSION

Diffuse proximity sensors with background suppression were designed to distinguish a target in front of a background, but a side benefit of the way background suppression works is that the sensor is not fooled by target color patterns and texture (Figure 13). Typical ranges are from 0 to 6 feet.

One implementation of background suppression utilizes 2 receivers behind the receiving lens. Just as our eyes provide us with stereo vision by giving our brain 2 images to compare, the background suppression sensor relies on 2 receivers that are adjusted so that they sense the pres-

ence of a target when the output of both receivers is equal.

Since equality of reflected light amplitude is the only characteristic sensed, it makes no difference whether white, grey, or any other color is present — or whether it fluctuates in amplitude as it would when encountering a textured surface or lettering or graphics on a container.

Applications:

- Material handling-conveying systems.
- Collision detection for AGVs (Automated Guided Vehicles).
- Car/truck wash.
- Level sensing.

COLOR REGISTRATION

Color registration is used in the packaging and material control industry to identify index marks of various colors, or the presence of labels on shiny surfaces (Figure 14). These units are characterized by fast response times and are capable of detecting small marks that pass the unit at extreme speeds. A demanding application might be the detection of a 0.03" mark that passes the unit at 9 feet per second.

The color registration sensor is a highly specialized diffuse proximity sensor which has the ability to detect fine changes in contrast on a surface. But unlike the standard diffuse proximity sensor, this type of unit uses a powerful lens system and must be positioned at a specific focal distance from the target.

Constraints of color registration scanning:

- Fixed distance.

FIBER-OPTIC SENSORS

What do you do when the physical constraints of the application don't allow for installing regular, self-contained sensors? Maybe the target is in a high temperature or chemically aggressive environment. Perhaps the target is small or very fast-moving. Fiber-optics, applied to photoelectric scanning, solves these problems (Figure 15).

The principle of conducting light around corners was discovered more than 100 years ago. However, the practical use of this principle is relatively new. It was accelerated by the development of communications, especially the need for noise-free data transmission. Medical imaging systems also played an important role in expanding the technology to the point of making it affordable for industrial and commercial use.

A fiber-optic cable is made up of a bundle of hundreds, and sometimes thousands, of glass or plastic fibers which are protected by a flexible armored sheathing. You can think of these as being analogous to conducting electricity using electric cables, only fiber-optic cables conduct light. All fiber-optic sensing modes are implemented using one type of amplifier which contains both emitter and receiver in one housing.

Using two opposed, individual fiber-optic cables, the object to be detected breaks the beam. The target must be at least the same dimension as the effective beam, which in this case is the bundle diameter. Because the beam is small, the detection can be precise. A typical application might be edge detection for a web printing press. Needle tips reduce the beam dimension for use with extremely small targets, typical for applications in semiconductors and pharmaceutical industries. Typical range of this type of sensor is 0 to 50 inches.

FIBER-OPTICS APPLICATIONS

When you mix the emitter bundle with the receiver bundle at the sensing tip, the result is a bifurcated cable. The setup is rather straight forward: the sensing tip must be placed close enough to the target to directly sense diffuse light.

This mode of scanning is the least precise because the properties of the target surface (color, shining, texture, etc.) greatly influence the quantity of light bounced back. However, it is the mode of choice for transparent targets. Typical range is 0 to 5 inches.

Typical applications:

- Small parts detection.
- Very fast moving targets.
- Edge detection.
- High temperature environment (600°F+).

□

CHAPTER 3

Inductive Sensors

Inductive sensors were developed as a noncontact alternative to the tried and true limit switch. Because limit switches require physical contact, they are prone to failure through wear, fatigue and accidental jamming. They also have mechanical contacts which can exhibit bouncing effects that PLCs don't like. The fact that inductive sensors are solid-state, and have no moving parts or bouncing effects, make them especially compatible with PLCs.

Inductive sensing technology was developed in what used to be West Germany and introduced to the U.S. marketplace about 20 years ago. To the credit of the technology's developers, inductive sensing is one of the best stan-

dardized technologies. This has helped the marketplace gain confidence in specifying this alternative to the limit switch.

INDUCTIVE PRINCIPLES

An inductive detector senses the proximity of a metal object using an oscillator principle. Surface currents, known as eddy currents, are induced in the metal target, and they react with the oscillator's field — the closer the proximity, the stronger the reaction.

When the metal target is outside of the oscillator field, the magnitude of the oscillations is not impeded. When the target is inside the field, it attenuates the magnitude of the oscillations, eventually stopping the oscillator. That's why it's named ECKO (Eddy Current Killed Oscillator). Figure 1 shows how the proximity of a metal target affects the magnitude of oscillations, the output voltage of the interface and of the output. The graphic shows how the threshold level detector (trigger circuit) shapes the output signal of the sensor into a clear-cut ON-OFF (here/not here) type of signal. If you look closely, you will notice that the ON point (operating level) is a different level than the OFF point (releasing level). The difference between these points is called differential or hysteresis.

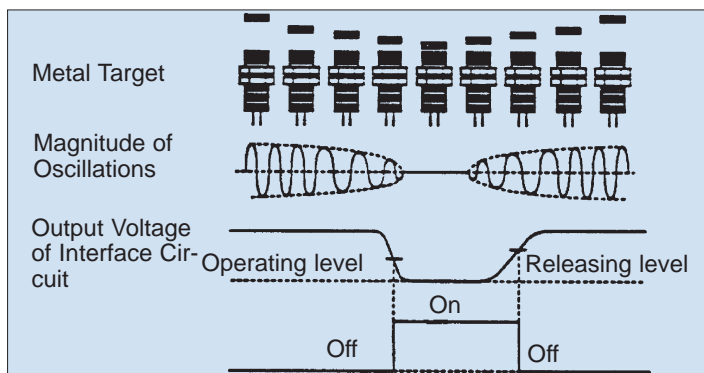

FIGURE 1. Schematic showing the principles of inductive sensing.

SENSING DISTANCE

Figure 2 shows a sensor and the field around it. This field is not an indication of sensing distance. The field is more intense around the sensor and less intense at its perimeter. (The perimeter P indicates the field limits within which the target-sensor interaction has a measurable effect.) If this were an analog system, the presence of metal would be detected at a weak level at the fringes and a strong level near the sensor.

If you introduce the standard target at different distances from the sensor, you will find that as the target gets farther away from the sensor, more metal has to enter the field to trigger the sensor ON. Finally, if the target enters the field at a certain distance from the sensor, there isn't enough metal in the field to trigger the sensor (Figure 3). If you plot all these points of entry that cause ON, you'll get a sensing distance curve that looks like Figure 4.

As we showed in Figure 1, a discrete system has a differential. That means that when we move the target back from the ON position, the sensor remains ON for the distance of the differential. We plot the OFF curve by introducing the target to the sensor until the ON point is triggered, then backing it away until the sensor triggers OFF (Figure 5).

The sensing pattern is 3-dimensional. It might help you to think of the shape as being like a brandy snifter turned upside-down. The cone-shaped area enclosed by the intersection of the sensing curves describes a sensing area that is used most in practical applications (Figure 6).

Figure 7 shows the sensing pattern graph for typical shielded and non-shielded inductive sensors. The horizontal axis gives the radius of the sensor from center, and the curves are each marked with the sensor diameter.

CALCULATING USABLE SENSING DISTANCE

There are 4 factors that will affect the performance of inductive sensors:

1. **Supply Voltage**
2. **Ambient Temperature**
3. **Target Material**
4. **Target Dimension**

GENERAL TERMINOLOGY

□ S_n = Nominal Sensing Distance

The rated operating distance for which the switch is designed, obtained using a standard target. This value should only be taken as a guide, since no manufacturing tolerances or changes in voltage or temperature are taken into account. It serves as a base for determining the usable range and for comparison between various designs and makes.

□ S = Usable Sensing Distance ($0.81 S_n < S < 1.21 S_n$)

Sensing distance S is an application design parameter used for selecting a specific sensor for an application. Relative to a standard target, the usable sensing distance takes manufacturing tolerances and external operating conditions into account. It is derived by testing with a standard metal target, during extremes of voltage and temperature variations. Generally 80% of the nominal sensing distance.

□ Effective (or REAL) Sensing Distance

This is the actual sensing distance realized by the actual sensor that you take out of the box and install in the actual application. The effective sensing distance will be no less than the usable, and is usually closer to the nominal in average circumstances.

□ Standard target

Used in the product laboratory to determine benchmark performance characteristics for a sensor. For inductive sensors, the standard target is mild steel that is 1mm in thickness and either:

1. A square with sides equal to the diameter of the sensing head for round sensors.
2. A square which is 3 times the nominal sensing distance for rectangular sensors.

□ Target

The actual object that needs to be detected by the proximity sensor. In real life, targets may differ from the standard, both in dimensions and in material. As a general rule, you should select a sensor with dimensions compatible with your target or smaller. If your target is small or made of a metal other than mild steel, you should carefully calculate the usable sensing distance, rather than rely on the 80% of nominal rule of thumb.

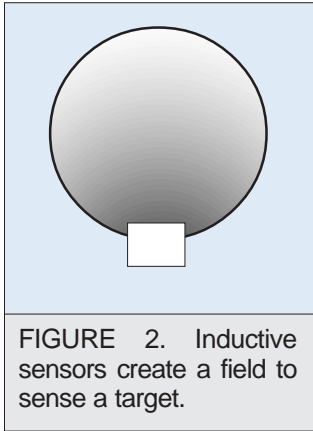

FIGURE 2. Inductive sensors create a field to sense a target.

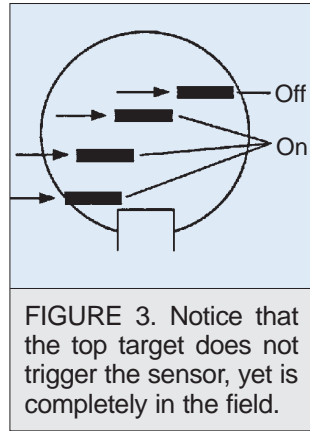

FIGURE 3. Notice that the top target does not trigger the sensor, yet is completely in the field.

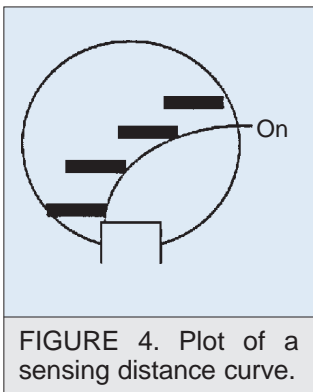

FIGURE 4. Plot of a sensing distance curve.

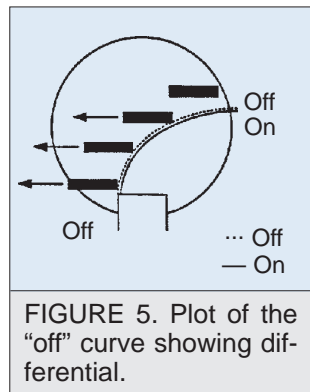

FIGURE 5. Plot of the "off" curve showing differential.

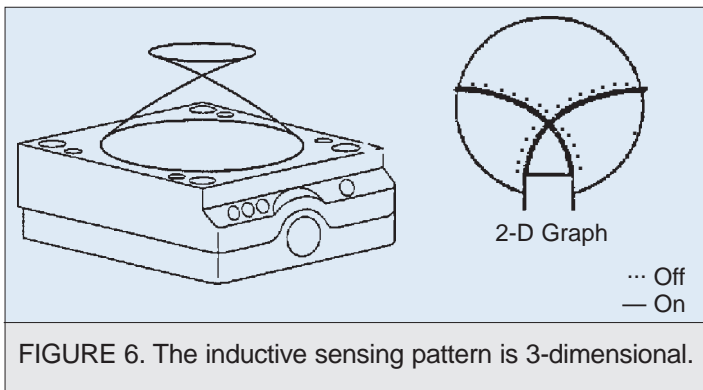

FIGURE 6. The inductive sensing pattern is 3-dimensional.

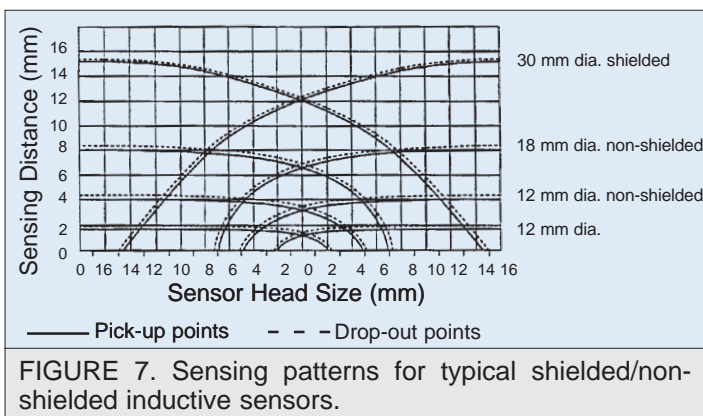

FIGURE 7. Sensing patterns for typical shielded/non-shielded inductive sensors.

To determine the *usable sensing distance*, apply this formula:

$$S = S_n \cdot K_t \cdot K_q \cdot K_m \cdot K_d$$

where:

S_n = Nominal sensing distance. The rated operating distance for which the switch is designed, obtained using a standard target.

K_t = Supply voltage coefficient. Use 0.9, which is the standard correction coefficient. This takes into consideration the maximum voltage variation within the rated voltage range.

K_q = Ambient temperature coefficient. The standard correction coefficient is 0.9, which is the worst case within the whole rated temperature range. Figure 8 shows a curve of K_q versus temperature. If your installation will be indoors and you need to squeeze maximum performance out of the sensor, the most conservative scenario might not be necessary to achieve full product confidence. As an example, for a temperature range of between 0°C and 50°C, a variation of no more than 3% might be adequate ($K_q = 0.97$).

K_m = Target material coefficient. Use data from Table 1 for mild steel, stainless, brass, aluminum, or copper. Mild steel is the standard target material, which has a coefficient of 1. Mild steel has the best characteristics for inductive sensing.

K_d = Target dimension coefficient. As a rule, you should select a sensor having comparable dimensions to that of your target. If your real target is smaller than the standard target, use data from Figure 9 to determine the correction coefficient. If the target is greater than or equal to the standard target dimension, use a coefficient of 1.

Most of the typical applications use targets that can be considered standard. Therefore, the usable sensing range (0.8 of nominal sensing distance) covers the maximum variation due to temperature (10%) and power supply (10%).

Example: What if the real target is mild steel but the dimensions are smaller than the standard target?

For a 120 mm rectangular sensor, a standard target is 120 x 120 mm. What if the real

target is 60 x 60 mm? Following Figure 9, locate 60 mm for a 120 mm sensor, and you will find that it is in column C. If you look up the coefficient for target dimension on the graph, you will find the value is $K_d = 0.9$. That means that the sensing distance for your real target should be 10% smaller than for the standard target. Therefore, from a nominal sensing distance of 40 mm, we find a usable sensing distance of 32 mm (.8 times the nominal sensing distance) and an effective sensing distance of $0.9 \times 32\text{mm} = 28.8\text{ mm}$.

Example: We need to sense a large aluminum target at a distance of 4 mm. To arrive at the nominal, we divide 4 mm by .8 because the usable sensing distance is 80% of the nominal. This makes the nominal sensing distance (S_n) equal to 5 mm. But, since the target material coefficient (K_m) equals .34 (see Table 1):

$$S_n = 5 / .34 = 14.7$$

Because we need a sensor with an S_n that's greater than or equal to 14.7 mm, we choose a sensor with the next standard nominal sensing distance. Conclusion: a 15 mm nominal sensing distance is required for sensing an aluminum target at a maximum of 4 mm.

INFLUENCE OF TARGET THICKNESS

Because the eddy currents are of the surface type (sometimes called “skin currents”), if the thickness of the target is lower than the current penetration, an interesting phenomenon happens — the sensing distance increases sharply — several times the norm. The parameters depend on the nature of the material.

Aluminum foil 0.01 mm thick results in the same sensing distance as mild steel. In applications where inductive sensing would normally be impossible due to the nature of the target, a thin coating of metal paint on the target can increase the usable sensing distance.

Suppose you wanted to detect the fluid level of the contents of a plastic vat. Mount the sensor to the wall, paint a ping-pong ball with aluminum paint or foil, mount a plastic conduit to the side of the tank, and float the ping-pong ball in the pipe. The sensor will detect the ping-pong ball through the wall as if the ball were made of steel.

Surface treatments (platings) can improve the properties of otherwise poor sensor materials. For example:

- A .2 mil thick plating of nickel on 1020 steel increases sensing distance by 1.6%.
- A .25 mil thick plating of tin on 1020 steel increases sensing distance by 4.2%.

REPEATABILITY

Repeatability is the precision of the sensor in its ability to repeatedly detect a target at a given point, taking into account a set of standardized operating conditions as environmental variables. Repeatability is expressed as a percentage of the effective sensing distance, such as: 8 hours, $T = 20^\circ\text{C}$, repeatability = $\pm 5\%$ of S_n , worst case.

Example: A 120 x 120 mm sensor has an S_n of 40 mm. Its usable sensing distance is 32 mm. Now let's take a sensor out of the box and put it in the application, and we find that it has an effective sensing distance of 32 mm. It would have a repeatability of 5% of 32 mm = 1.6 mm, so every time the target approaches the sensor frontally, the sensor triggers at a distance of anywhere between 30.4 and 33.6 mm, depending on the real temperature and power supply value.

A side approach closer to the sensing surface is recommended when more repeatability is desired. At 5 mm from the sensor moving sideways, the same target will be detected within $\pm 0.015\text{ mm}$ of the effective distance.

Not all applications require a high level of repeatability.

Example: You are filling an aluminum can that must have a positioning accuracy of $\pm 1/16$ inch at the filling station, otherwise you have product spilling on the floor. Does your choice of sensor have the repeatability to achieve this all day long, despite changes in supply voltage and temperature?

TABLE 1 — TARGET MATERIAL COEFFICIENT K_m

Material	Mild steel	Stainless steel	Brass UZ33	Aluminum AU4G	Copper
K_m	1	0.35-0.65	0.38	0.34	0.27

SHIELDED AND NON-SHIELDED INDUCTIVE SENSORS

A sensor has a field which extends around the front surface to the sides of the unit. If metal is brought into the field without triggering the output, the sensing distance and pattern of the sensor will not be predictable. You will recall that the amount of metal in the field is what causes the sensor to trigger, and if there is already metal in the field before the target enters, the field is preloaded, causing the target to be sensed prematurely. Common situations for having a preloaded field are when the sensor is mounted in metal or when metal is in the background.

Because most of the time the ability to mount a sensor in metal is desirable, we need to cancel the influence of the metal preloading the field. If we introduced metal into the field in a controlled manner (by incorporating it into the sensor itself), the sensing pattern becomes predictable. This sensor can now be flush mounted. This type of sensor is called *shielded*, as opposed to *non-shielded*. You should note that the shielding that makes flush mounting

possible also reduces the sensing distance. Plastic sensors can also be shielded. As with sensors having metal bodies, the shielding is on the inside of the housing.

MOUNTING RECOMMENDATIONS — TUBULAR SENSORS

To install a non-shielded sensor in a metal environment, an area 3 times the diameter must be cleared and recessed to a depth of twice the nominal sensing distance (Figure 10). An L-bracket is commonly used for mounting. However, it is recommended that mechanical stops be installed to protect the unit from physical damage. Mounting the sensor in C-channel can also protect the sensor, but be sure that field clearances are observed.

Compare the ease of installation for the shielded sensor (Figure 11) to the non-shielded. Flush mounted sensors have a better chance of surviving mechanical shocks because the fixture protects the unit. If the usable sensing distance of the shielded sensor suits the application, it presents the least amount of mounting considerations.

MOUNTING RECOMMENDATIONS — RECTANGULAR SENSORS

Shielded models can be mounted on metal plates without any problem. The non-shielded sensor (Figure 12) can be mounted directly from the side to a nonmetallic surface, but it must be kept at least 1.5 times its width from other metal objects or fixtures on two of the three other sides (Figure 12A). If it will be surrounded by metal on three sides, a distance of twice the sensor's width must be maintained

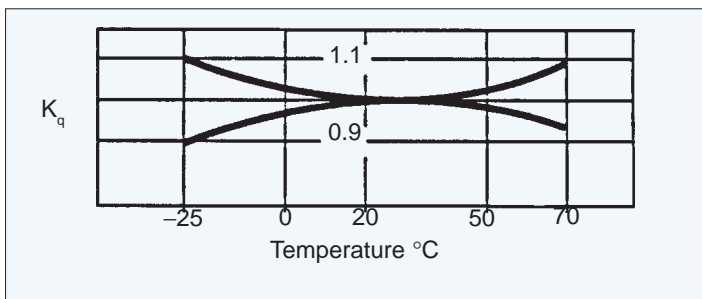

FIGURE 8. Graph of ambient temperature coefficient (K_q) versus temperature.

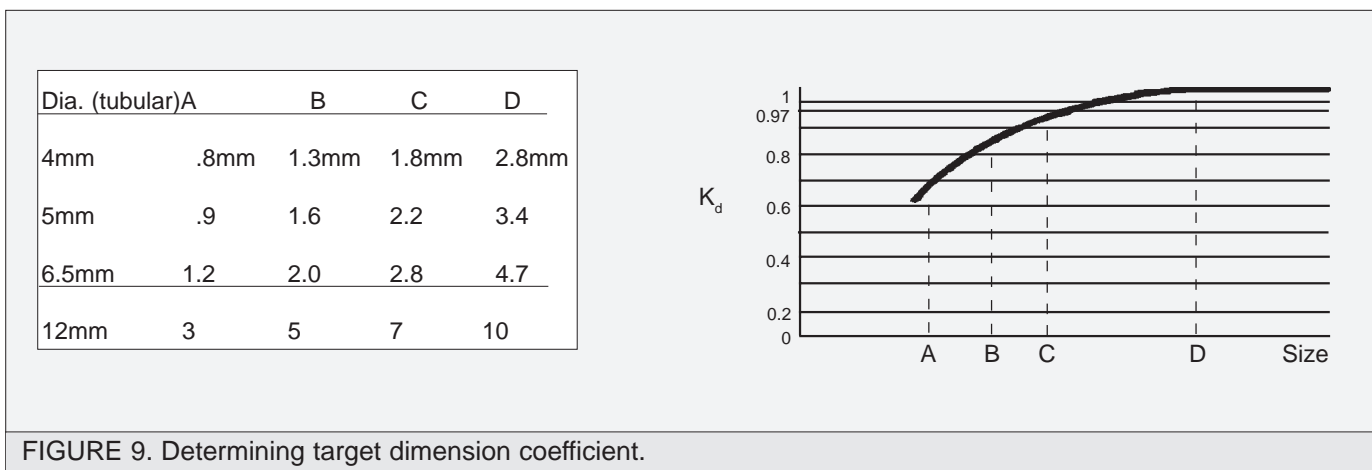

FIGURE 9. Determining target dimension coefficient.

(Figure 12B).

The non-shielded sensor can be directly mounted from its back to a metal surface. Metal must be kept away from the front of the sensor a distance of three times the nominal sensing distance (Figure 12C). If the sensor is to be mounted near metal on one side, it cannot be mounted any closer than 1.5 times the sensor's width. If the sensor must be recess-mounted in metal, a clear area of twice the width of the sensor must be maintained (Figure 12D).

MUTUAL INTERFERENCE

If 2 sensors are positioned too closely, the frequency of one mixes into the detecting coil of the other causing output to latch in the ON position without a target being present. This can be overcome by either maintaining the recommended side-by-side spacing, or some models have the ability to have their oscillating frequency altered at the factory. The latter are referred to as "alternating frequency" models and can be mounted side-by-side without any problem.

With regular sensors, the way to guard against mutual interference for side-by-side mounting is to maintain an interval twice the nominal sensing

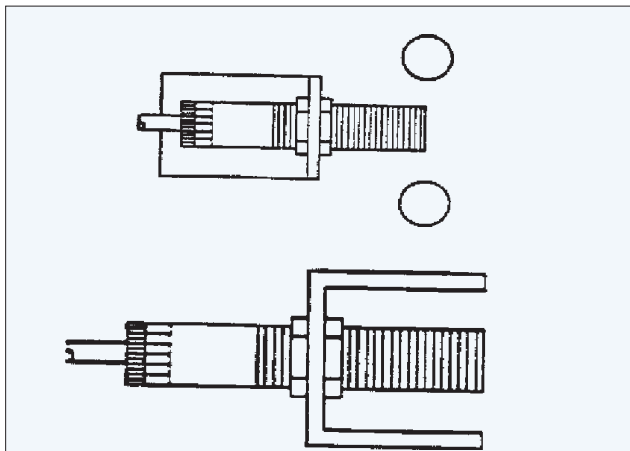

FIGURE 10. Mounting recommendations for non-shielded sensors.

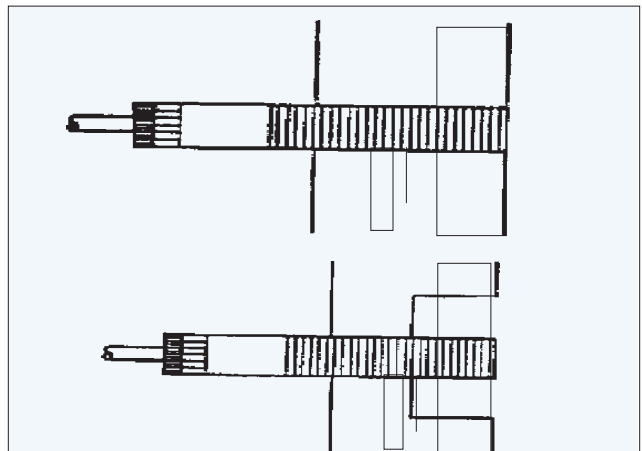

FIGURE 11. Mounting recommendations for shielded sensors.

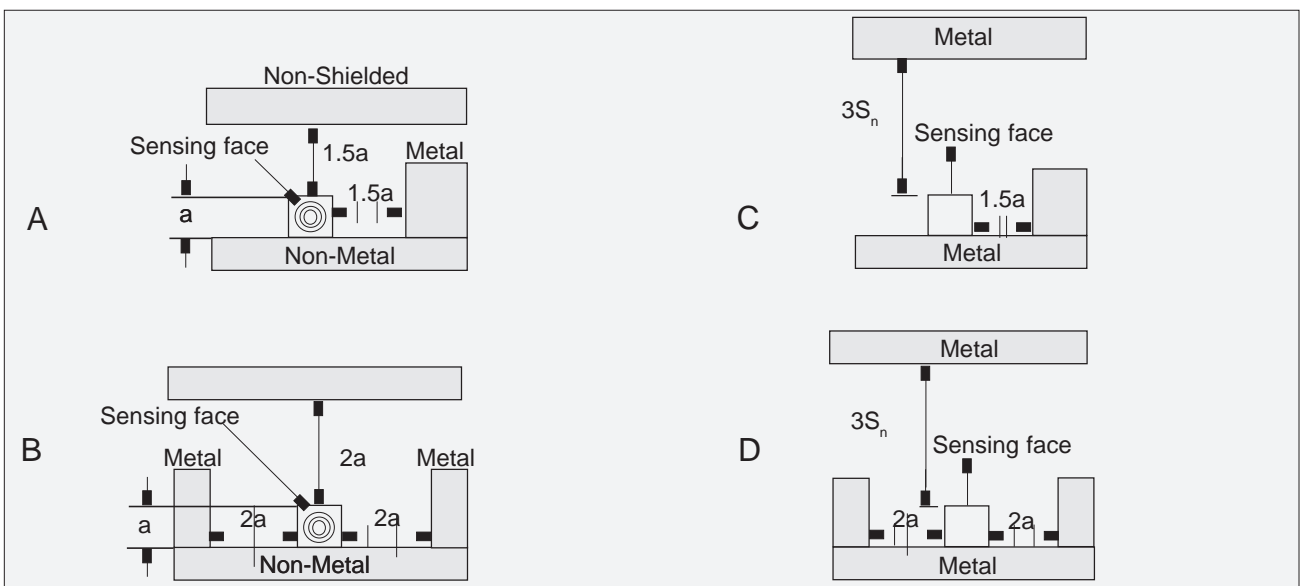

FIGURE 12. Non-shielded rectangular sensor mounting.

distance. If the fields oppose each other, they must be kept apart by a factor of ten times their nominal sensing distance.

WELD FIELD IMMUNE (WFI)

The electric welding process generates a strong electrical field near the welding points. This field can interfere with the normal operation of an inductive proximity sensor situated nearby, creating false output signals. Normal inductive proximity sensors should not be used for such applications. Specially designed sensors, called weld field immune, can be used as close as 1 inch from the welding point.

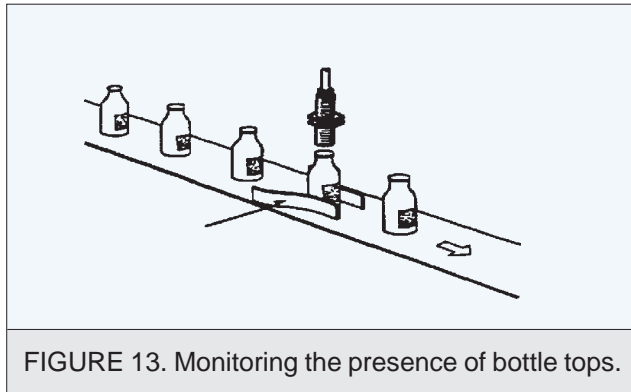

FIGURE 13. Monitoring the presence of bottle tops.

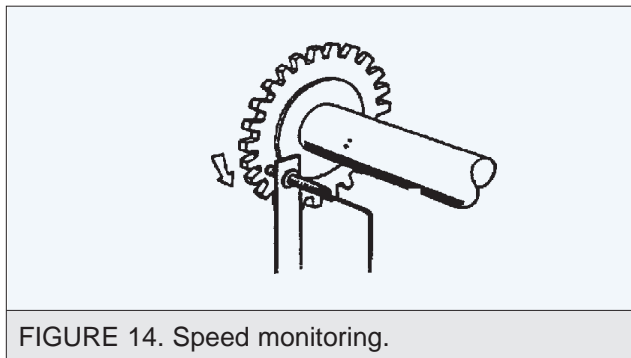

FIGURE 14. Speed monitoring.

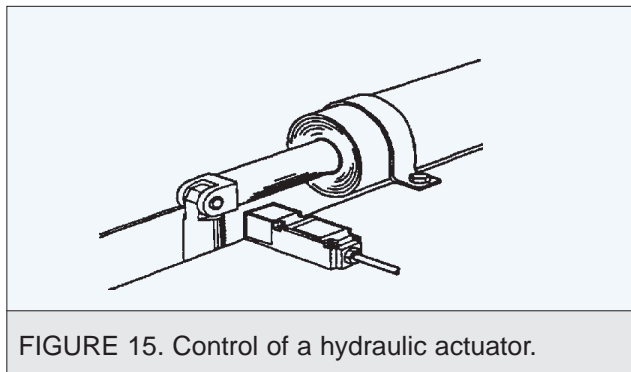

FIGURE 15. Control of a hydraulic actuator.

RADIO FREQUENCY IMMUNE (RFI)

Radio frequency fields also can induce false signals. Typical examples are walkie-talkies — used quite frequently on the factory floor. Special techniques are used to create radio frequency immunity. Today RFI sensors can actually be touched with the walkie-talkie antenna while it transmits without changing the output of the proximity switch.

VARIABLE SENSING DISTANCE

Few inductive sensors are available with an adjustable sensing range. This usually undesirable feature is sometimes recommended for situations where you have metal in the background of long range sensors. The sensitivity adjustment should be decreased to reduce the background influence and make target detection look “normal.”

APPLICATIONS

Figures 13-15 illustrate some common applications of inductive sensors. □

CHAPTER 4

Output Theory

The two basic sensor output technologies are electromechanical and solid-state.

Electromechanical: This is a switch which physically opens and closes a circuit (Figure 1). There is no voltage required to power the relay — that’s what we mean by “dry contact.” There is no voltage across the switch when the circuit is closed. Its physical position determines the circuit’s status. Electromechanical switches are either normally open (NO) or normally closed (NC). Examples of electromechanical switches include contacts, relays, reed relays, push-button operators, and limit switches.

Electromechanical switches have several advantages:

- Universal — the same switch can be used with either AC or DC.
- Excellent for withstanding line transients because an air gap is an excellent isolator.

- There is practically no voltage drop when the switch is closed, and there is no leakage current when the switch is open.
- When the circuit is closed, very little heat builds up because the voltage drop is negligible.

The disadvantages of electromechanical contact follow:

- Wear is always a factor when dealing with devices that have moving parts.
- Because moving parts have inertia, the switch is relatively slow. The exception to this is the reed relay, which is extremely fast because the reed has virtually no inertia.
- Electronic noise can be generated when the contact opens on inductive loads. RC networks and surge suppressors are recommended for critical applications.

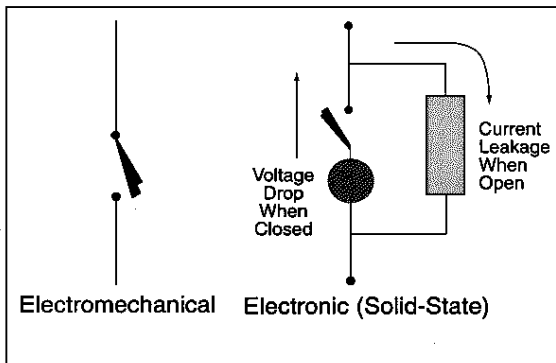

FIGURE 1. The two types of sensor output technology.

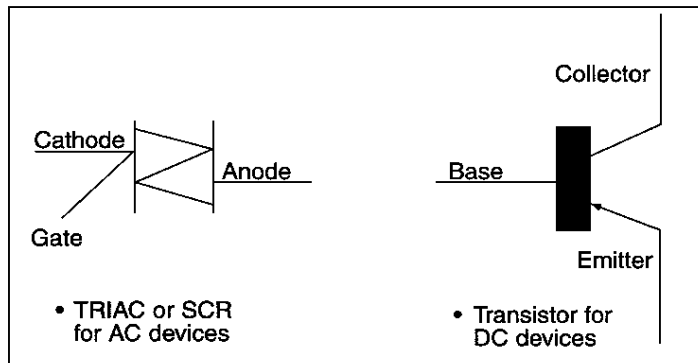

FIGURE 2. Circuit representation of a TRIAC and a transistor.

- For low energy applications (5-12 VDC, 0-15mA), silver contacts oxidize over time and stop conducting. More expensive gold contacts don't oxidize and can be used for low energy applications.

Solid-State (electronic): As the name implies, solid-state switches have no moving parts. Power is required by the solid-state switch at all times. These switches need a certain amount of current to energize the circuitry and the output, and there is voltage across the switch even when the circuit is closed. When it's open, there is a certain amount of current (leakage current) passing through it. Examples of solid-state switches include transistors, TRIACs, and SCRs.

There are some important advantages to solid-state switches, such as:

- Wear is not a factor, because there are no moving parts.
- The switches operate extremely fast, because inertia is not a factor.
- AC switches do not generate noise and transients as a result of arcing. They stop conducting when current reaches zero. Therefore, there is no energy left to generate arcing.
- The devices work extremely well at low energy — especially DC switches.

The disadvantages of solid-state switches include:

- Solid-state switches must be powered at all times. When they are open, leakage current flows through the load. When they are closed, there is a voltage drop to power the switch which must be considered. Leakage current can be microamps

or milliamps in magnitude. Depending on the technology and the amount of current conducted, voltage drop can be millivolts up to several volts.

- Transients in the power supply can send false signals to the switch, or even cause it to fail completely. Clean power is essential.
- Solid-state switches, while well-suited for low-energy applications, have difficulty with high-current applications. Because of the voltage drop, these switches generate heat. At current levels above 0.5A, these sensors need bulky heat sinks to dissipate the heat.

SOLID-STATE SWITCH TECHNOLOGY

We said that electromechanical switches are universal — that AC or DC will work with the same hardware. This is not the case with solid-state switches. AC devices use TRIAC or SCR switches; DC devices use transistors.

TRIACs have an anode and a cathode (Figure 2). The status of the switch is controlled by a gate signal from the sensor electronics. Transistors have an emitter and a collector. The status of the switch is determined by a signal to the base.

TRIAC CIRCUIT (AC)

When a gate signal from the sensor technology is applied to the cathode, this “fires” the TRIAC switch and it will start conducting (Figure 3). This should be considered a normally open circuit.

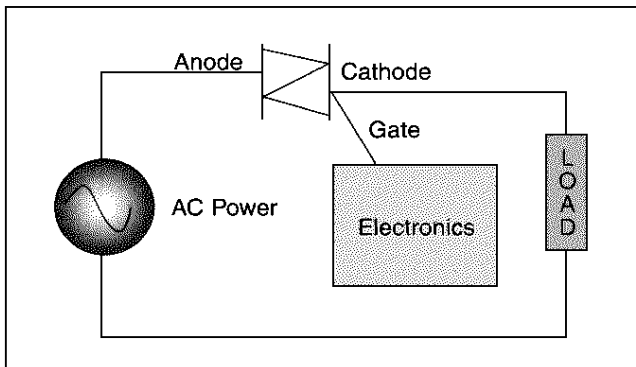

FIGURE 3. An example of a TRIAC in an AC circuit.

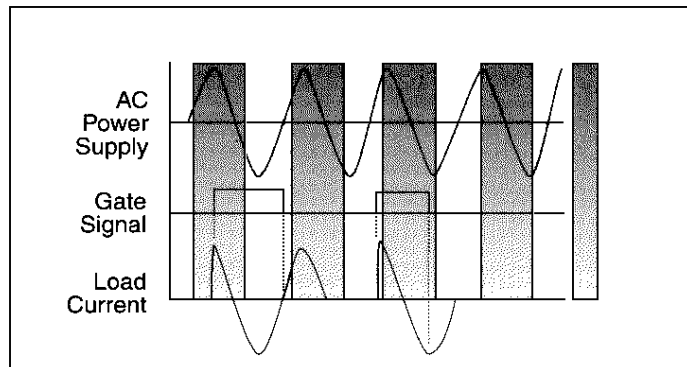

FIGURE 4. Conduction of a TRIAC due to a gate signal.

The TRIAC must be loaded with a minimum current, otherwise it will stop conducting. Old generation TRIACs require 15-30mA, while new generation TRIACs require only 5mA or less.

Figure 4 shows what happens when the sensor electronics initiate a gate signal to the cathode. It “fires” the TRIAC immediately and the TRIAC conducts; current flows through the load. When the gate signal stops, the TRIAC will continue to conduct until the power supply current reaches zero. The TRIAC must be retriggered every half cycle to continue conducting.

One-half cycle is also the TRIAC’s and the sensor’s minimum response time, as shown in the first gate signal. The gate signal started during the positive half cycle of the load current. The load current will end at its next zero crossing, after the gate control voltage is removed.

If it were an ideal switch, the TRIAC would have stopped conducting precisely when the gate signal stopped. However, the characteristic of the TRIAC is such that it can only “power down” when the power supply current is at zero. TRIACs and SCRs cannot be used in DC applications because they cannot be stopped at all.

TRANSISTOR SWITCHING FOR DC

Transistors are polarity sensitive. They permit current to pass in only one direction. (That’s why they can’t be used with alternating current.) In the environment of DC circuitry, current flows from positive to negative.

There are two kinds of transistors which are used for two basic situations:

1. NPN connects the load to the negative (Figure 5). This is called *sinking*.
2. PNP connects the positive to the load (Figure 5). This is called *sourcing*.

If you tried to connect a sourcing load to a sourcing switch, there would be no flow of current because neither is conducting to negative. If you tried to connect a sinking load to a sinking switch, both would be connected to ground and there would be no positive.

THREE-WIRE TECHNOLOGY

The elements of three-wire technology are the positive, the negative and the output (Figure 6). You will usually associate three-wire technology with DC applications. However, if you encounter an AC three-wire circuit, the terms are the live, the neutral and the output.

As a general rule, three-wire devices have the signal electronics powered separately from the output circuit. The output is usually wired internally to one of the power terminals. The load is wired externally between the output and the other power pole, closing the circuit.

The advantage of this setup is that the power supply current doesn’t pass through the load. The switching characteristics are the best that output switch technology can offer — i.e., low voltage drop and very low leakage current. The disadvantage is that it has one more wire than electromechanical switches, with the attendant higher cost for cable and greater chance for confusion.

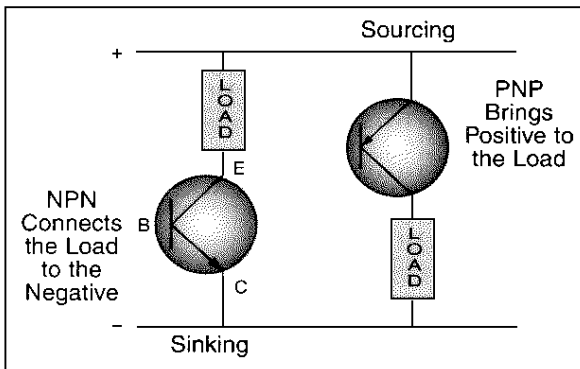

FIGURE 5. Transistor switching for DC.

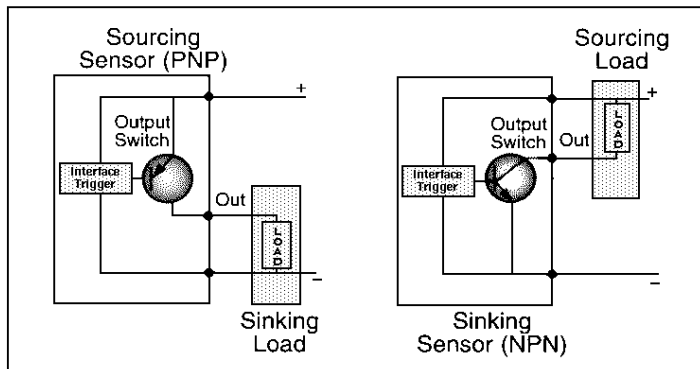

FIGURE 6. Examples of three-wire technology.

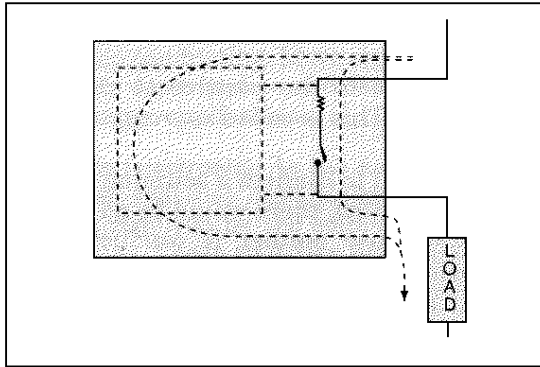

FIGURE 7. An example of two-wire technology.

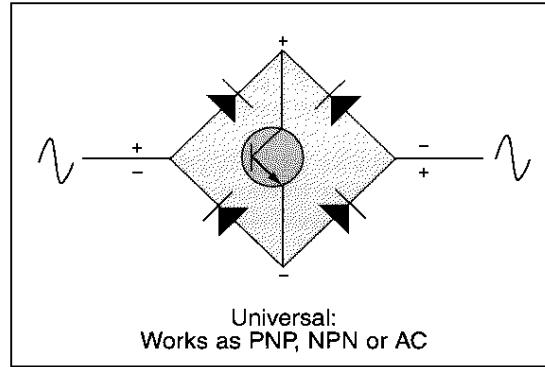

FIGURE 8. AC/DC two-wire technology.

Mnemonic Rule. Many users have difficulty matching the type of sensor (NPN/PNP) with the type of load (sinking, sourcing). There is a simple rule. The sensor is always wired the same way: +, - and load. The only variable is where the other end of the load is wired (Figure 6). The middle letter in the sensor type (NPN or PNP) indicates where the other end of the load should be wired. For example, if you have an NPN (sinking) sensor, the load should be connected to *positive*. For a PNP (sourcing) sensor, the load should be connected to *negative*.

TWO-WIRE TECHNOLOGY

When the circuit is closed, a small amount of energy is diverted from the main circuit to power the electronics (Figure 7) with two-wire technology. The electronics require a supply voltage at all times. The output switch cannot close in parallel because it would short circuit the electronics. A resistor (R) in series with the output switch represents the power supply circuit. Obviously, the current passing through it creates a voltage drop, which is higher than the three-wire case where we have only the switch in the circuit.

However, for most applications, the voltage drop (V_d) is well within the operating range of the load. Yet, when several sensors are wired in series, this voltage drop can be considerable. In two-wire configurations an amount of current is moving through the load even when the switch is open. The current is higher than the leakage current of the switch proper because it also has to power the electronics. This is fine for loads that require a threshold amount of current before they work, but in very low-energy

loads, leakage current can become a concern, especially if many sensors are used in parallel.

In AC circuits, the leakage values of current and voltage are not significant for many loads. This explains why two-wire technology is used almost exclusively in AC. In low-energy DC circuits, leakage values might create problems. Although three-wire technology is still prevalent in DC, two-wire DC is starting to gain acceptance, especially when used with PLCs. At low current, the voltage drop is relatively small and the leakage, using modern semiconductor technology, is no longer a problem.

CAUTION: There are AC two-wire devices with three physical wires. The third is the CHASSIS GROUND and should not be counted because it has no functional role in the circuit.

AC/DC TWO-WIRE TECHNOLOGY

Diodes only permit current to flow in one direction. When they are put together around a transistor, as in the configuration of Figure 8, current flows through the switch (i.e., transistor) in only one direction, regardless of the outside voltage polarity. This diode bridge creates a universal switch: AC and DC can be conducted through it, and it can be used as either a PNP or NPN in a DC circuit. The disadvantages of the diode bridge are higher voltage drop and higher cost. □

CHAPTER 5

Interfacing Sensors With Loads

The two most common types of loads that we will discuss are *resistive* (e.g., lamps, heaters, solid-state relays and PLC input modules) and *inductive* (e.g., relays and solenoid valves).

RESISTIVE LOADS

Common resistive loads do not pose any problems interfacing sensors as long as the current is within the sensor specified range.

Resistive loads that warm up significantly when activated, such as lights and heaters, present a problem. Their cold-state resistance can be 10 times lower than their hot-state resistance, causing high current levels when turning ON. So high, in fact, that they can cause sensor failure or, for sensors so equipped, short-circuit protection circuits to engage. A resistor wired in parallel with the switch keeps the load warm, raising the resistance to levels that are well within the specifications of the switch (Figure 1) but low enough not to cause visible effects.

PLC INPUT MODULES -TWO-WIRE AC

PLC (Programmable Logic Controller) input modules are another example of a resistive load. In principle, they require little energy; their internal requirements are in the

low milliamps. You can think of the role of PLC input modules as "signal switching" rather than "power switching." The current for input modules was made artificially higher than required, in the range of 12 to 16 milliamps, because the modules originally were designed for electromechanical switches with silver contacts. These contacts develop an oxide film on their surface, but arcing cleans this film away. To promote arcing, the current to be interrupted must be a minimum level - 15 mA at 24 V or higher. This is an established industry standard.

PLC input modules have been designed to provide a wide latitude for signal switching. They are ideal loads for sensors because they do not require much current from the sensor. This is why two-wire technology started to gain acceptance.

In order for a two-wire AC switch to be directly compatible with a PLC, two conditions must be met:

1. PLC Requirement: Leakage current must be less than 1.7 mA when the switch is off (rule of thumb). This level is below the standard PLC threshold for OFF state. If the leakage current of the sensor is greater than 1.7 mA, the PLC will be ON all the time, regardless of the condition of the switch.

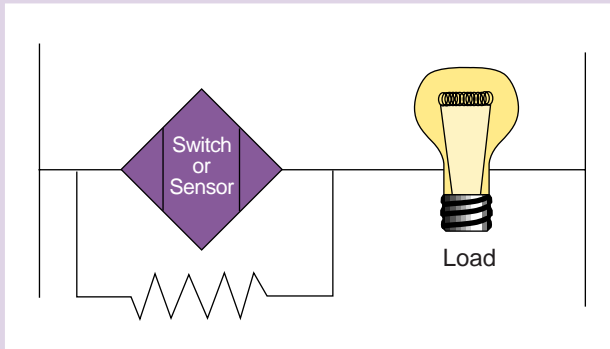

FIGURE 1. Wiring resistive loads to correct for cold state.

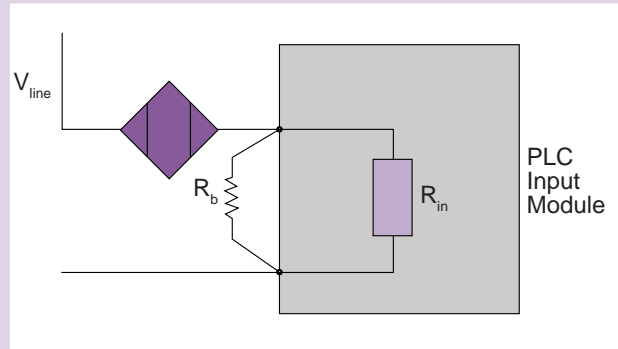

FIGURE 2. Wire bleeder resistor in parallel with load.

2. Switch Requirement: Load current must be greater than the switch minimum rated value when the switch is ON. Rule of thumb: if the switch minimum current is above 20 mA, it will not work with most PLCs.

A method to satisfy these requirements is to use a bleeder resistor in parallel with the load (Figure 2). You dimension the bleeder in such a way that, when the switch circuit is closed, it will make up the difference between the minimum current required by the switch and the current required by the PLC input module (switch requirement).

When the switch's minimum load current is greater than the PLC's load current during the ON state, the bleeder resistor is dimensioned using the following formula:

$$I_{\text{bleeder min}} = I_{\text{switch min}} - I_{\text{input PLC}}$$

$$R_{\text{bleeder max}} = \frac{V_{\text{line}}}{I_{\text{bleeder min}}}$$

Typical values for PLC input resistance are between 7.5 to 10 kΩ. NOTE: The value should be kept close to the maximum value determined by the formula in order to minimize heat dissipation. The smaller the resistor, the higher the dissipated power (power = heat).

When the sensor's leakage current is greater than 1.7 mA during the OFF state (PLC requirement), the bleeder resistor must be dimensioned using the following formula:

$$R_{\text{bleeder max}} = \frac{R_{\text{in}} \cdot V_{\text{o max}}}{(I_{\text{off}} \cdot R_{\text{n}}) - V_{\text{s}}}$$

$$P_{\text{b min}} = \frac{(V_{\text{s}})^2}{R_{\text{bleeder max}}}$$

where:

- R_{in} = the input resistance of the PLC module or any input of a similar solid-state device.
- $V_{\text{o max}}$ = the PLC maximum OFF voltage (usually 20 - 40 V AC).
- V_{s} = the power supply voltage.
- P_{b} = the minimum power rating of the bleeder resistor. It needs to be calculated in order to avoid overheating and self destruction.
- I_{off} = the leakage current of the actual sensor.

PLC INPUT MODULES - THREE-WIRE DC

PLC input circuits are identical for sinking or sourcing input modules. The difference is the common wire. To reduce wiring and the number of connectors:

- Sinking PLC input modules have all the negative terminals internally bussed to one terminal.

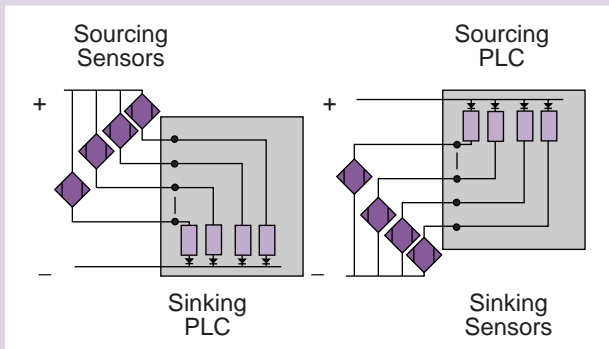

FIGURE 3. Connecting sensors to a PLC using three-wire DC.

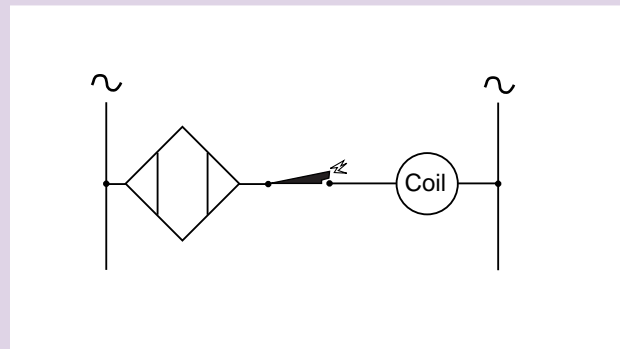

FIGURE 4. Electromechanical switches create transients.

- Sourcing PLC input modules have all positive terminals internally bussed to one terminal.

To complete the circuit, sensor must be complementary to the PLC. By complementary we mean that a *sinking PLC input module must have sourcing sensors and a sourcing PLC input module must have sinking sensors*. The industry is pretty well established in the use of the terms sinking and sourcing, but there are exceptions. Be aware of this and check the PLC wiring diagram. The industry is in the process of standardizing these concepts to avoid any confusion.

INDUCTIVE LOADS (AC)

When inductive loads conduct, they accumulate energy. When these circuits are interrupted, the accumulated energy must be dissipated. Electromechanical switches typically arc as they are opened with inductive loads; the arc dissipates the energy (Figure 4). When solid-state devices are not used, the transients generated by this process are not a problem, even though arcing will degenerate the contacts of electromechanical switches. However, these transients can destroy solid-state devices in an instant.

Because AC solid-state switches (TRIACs and SCRs) stop current at a zero crossing - when no energy is present - there is no energy to dissipate when they interrupt an inductive circuit. Therefore, AC solid-state switches do not gen-

erate transients. This explains why there is no problem using only solid-state switches for AC inductive loads.

The only problem is when both solid state and electromechanical devices are used to switch the load (Figure 4). The solution is to dissipate surges in the line caused by the electromechanical contact when interrupting the current. An MOV (metal oxide varistor) or similar device is put in parallel with the load (Figure 5) to absorb the energy surge. The MOV is a variable resistor which changes its value in the presence of increased voltage. The higher the voltage, the lower the MOV's resistance value. When the MOV "sees" the increased voltage, it opens up and diverts the surge. This not only protects the solid-state device, but substantially reduces arcing in the electromechanical device, which also prolongs its service life.

INDUCTIVE LOADS (DC)

In DC, when the inductive circuit is opened, the polarity reverses until the energy is dissipated. This results in an arc across the electromechanical switch, or an overvoltage across the solid-state ones. The overvoltage across a blocked (OFF) solid-state switch tends to permanently damage the blocking capability of the switch in the OFF state. Most solid-state sensors today have an internal mechanism in parallel with the switch that opens only in these circumstances and directs the coil energy safely to the power supply.

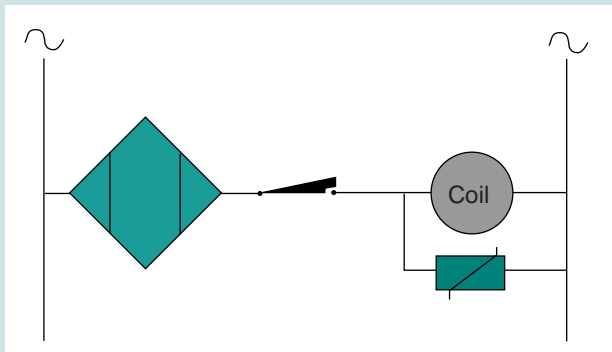

FIGURE 5. MOV surge suppressor protects both solid-state and electromechanical switches.

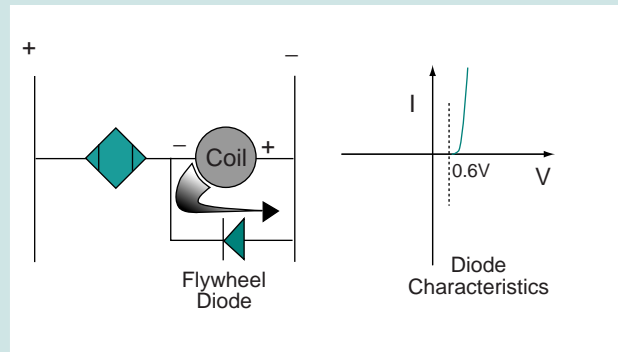

FIGURE 6. Use of a flywheel diode to protect solid-state switches.

To protect solid-state switches without this protection, a flywheel diode is wired between the coil and the sensor (Figure 6). When the polarity changes as the circuit is broken, the energy is safely dissipated through the diode back to the negative terminal. Fast diodes are recommended for this application.

WIRING IN SERIES

Normally-open sensors in series with the load perform the AND function, while normally-closed sensors perform the OR function.

The maximum number of sensors in series is restricted by supply voltage, the voltage drop across each sensor, and the minimum operating voltage of the load. When you have a number of switches wired in series, their combined voltage drop might reduce the available load voltage to a level that is too low to activate the load.

We need to provide enough voltage to the load to energize it. To determine the maximum number of sensors we can wire in series, use the formula:

$$\text{Number of sensors} = \frac{\text{Supply Voltage} - \text{Minimum Operating Voltage of Load}}{\text{Voltage Drop Across Each Sensor}} - 1$$

For two-wire types of sensors another major requirement is to provide enough supply voltage for each of the sensors wired in series. They need to work properly when in the OFF state. Divide the minimum line voltage by the number of sensors you intend to use. The result should be within the sensor supply operating range.

Figure 7 shows an example of two sensors used in series. Suppose the line voltage is 110 V AC, and each sensor requires 93 to 134 V AC. If 100 V AC is the minimum line voltage, the available voltage to power each sensor ($100 \text{ V} / 2 = 50 \text{ V}$) is insufficient.

In the example of Figure 8, we use *extended range* sensors, each having an operating range of 20 - 264 V AC. Now 50 V AC is enough to power each of these two sensors. In fact, up to four extended range sensors can be used in series with this load.

WIRING IN SERIES - THREE-WIRE TYPE

Solid-state devices have consumption currents that are a concern. In Figure 9, notice that in addition to the load current, sensor number one handles the consumption currents for the rest of the sensors.

Notice that when sensor one is OFF, the other two sensors have no power and are not able to detect a target. When the first sensor comes ON, the next sensor in line must first "warm up" before it can detect a target. Since it is also

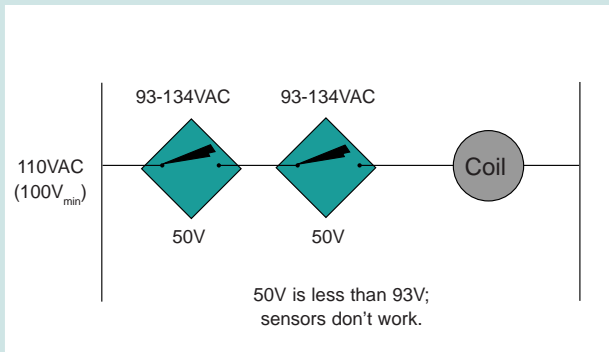

FIGURE 7. Narrow range sensor application in series (OFF state).

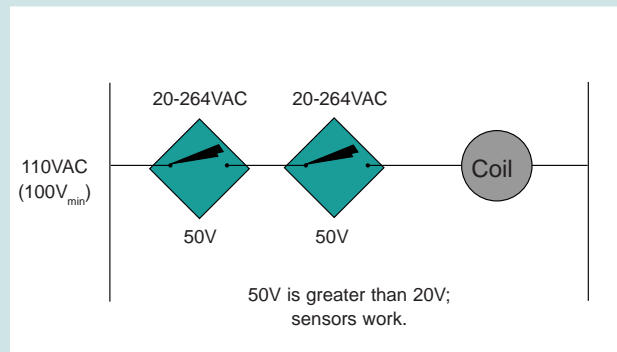

FIGURE 8. Extended range sensors wired in series (OFF state).

a normally-open switch, the third sensor has not received any power yet, and its power-up time must be added in evaluating the total response time.

WIRING IN PARALLEL - TWO-WIRE TYPE

When sensors are wired in parallel, normally-open switches perform the OR logic function, and normally-closed switches perform the AND function (Figure 10).

The maximum number of sensors is restricted by the minimum ON current of the load - the sum of the leakage currents must be less than the minimum ON current of the load.

$$\text{Number of sensors} = \frac{\text{Holding Current of the Load}}{\text{Leakage Current}} - 1$$

When one sensor is ON, it short circuits the rest of the sensors. The response time of the sensor two through n is affected by their power-up delay. For instance, assume sensor 1 is ON. Sensor 2 "sees" a target but is not working because sensor 1 practically short circuits it. When sensor 1 turns OFF, sensor 2 doesn't turn ON immediately because it was just powered-up. Only after its power-up delay will it respond to the target presence.

WIRING IN PARALLEL - THREE-WIRE TYPE

In the example (Figure 11) of three-wire DC technology, each of the sensors is now fully activated without the need for power-up time.

There are practically no restrictions to the number of devices used in parallel because the leakage current is relatively small. However, when a large number of sensors is wired in parallel, check the sum of the leakage currents against the load's maximum OFF threshold - don't exceed it.

WIRING ADVICE AND SHORT-CIRCUIT PROTECTION

Don't try to economize by running power cables with control cables, just because it might be easier. Control cables have very low energy signals that should be shielded from the fields of power cables. Power cables can induce transients just by being close to the control cables because the long run of wire acts like a big antenna. Always use separate cable runs. Your extra effort in setup will reward you with a smooth running system.

Do not connect an AC switch directly to a supply source. Doing so will destroy the switch unless a short circuit protection option is used. A suitable load must be wired in series with the switch - even for testing.

* Caution for multiple sensors applications: Whenever possible, use one sensor in load circuits. Load circuits with multiple sensors are more difficult to design and troubleshoot. Try to avoid mixing solid-state and electromechanical switches in the same circuit.

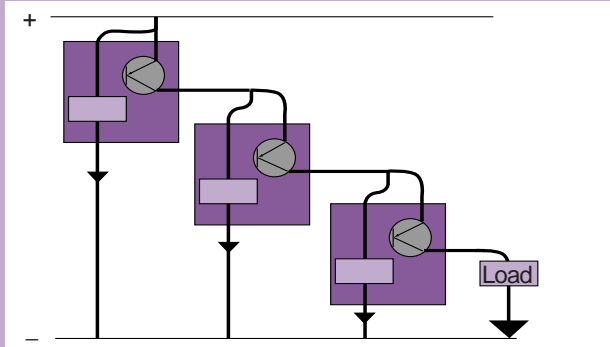

FIGURE 9. Three-wire sensors wired in series.

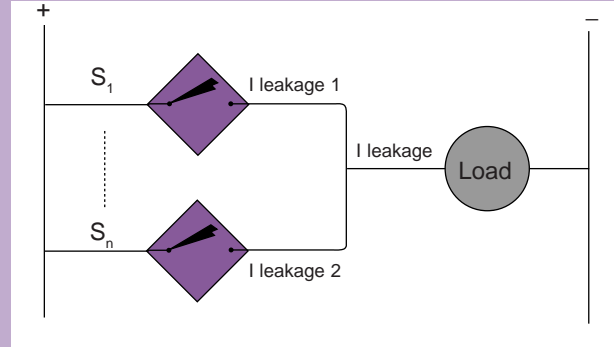

FIGURE 10. Wiring sensors in parallel.

Probably the most common situation for a short circuit is during the installation of the wires into screw-type terminal blocks. Stray wire strands can touch other terminals, by-passing the load, and then your sensor is destroyed - unless you have short-circuit protection.

Short circuit protection (SCP) is a practical feature for switches to have in industrial environments. Once triggered, it blocks the current, effectively protecting the switch from destruction.

Short circuit protection (SCP) should not be used with loads such as lamps and heaters. When these loads are cold, they will trigger the SCP electronics.

There are two basic types of short circuit protection.

Automatic Reset: When the threshold is reached, the power is shut off, and the SCP electronics sample the condition of the power supply at short intervals to see if the short is still there. When it samples, it only closes the circuit for 2 or 3 μs , which is too short a time to cause any damage to the solid-state circuitry. When the sample shows that the circuit is back to normal, the SCP electronics automatically rest, and the device operates normally. Automatic reset is only a DC feature because AC switches cannot be closed by a control signal in such a short time. Automatic reset is common in DC devices. Many users consider it conve-

nient because it does not react to common transients in a visible manner.

Manual Reset: When the threshold is reached, the power has to be shut down. Someone must then correct the problem, power up and manually reset the device before it will operate normally again. For safety reasons, the manual reset is considered the best because it forces the operator to check the source of the problem. It is primarily found in AC circuits, but some situations warrant the added safety of manual reset in DC applications.

DC POWER SUPPLIES

The mechanics of converting an AC power supply to DC involves a few steps (Figure 12). First, a transformer steps 110 or 220 volts down to typical levels for DC applications (V_g). As a general rule, a transformer is selected having a lower secondary voltage than the required DC voltage - i.e., 18 V transformer to obtain 24 V, or 36 V transformer to obtain 48 V.

Next, a diode bridge rectifies the AC current. At this point, the power supply is DC, but watch the instant values. At each half cycle the voltage goes down to 0 V. A sensor rated as being able to operate on between 10 to 30 VDC will not work properly because the supply voltage goes under its absolute minimum: 10 V.

To correct this, a smoothing capacitor filter is added to achieve V_s . During the peak, the ca-

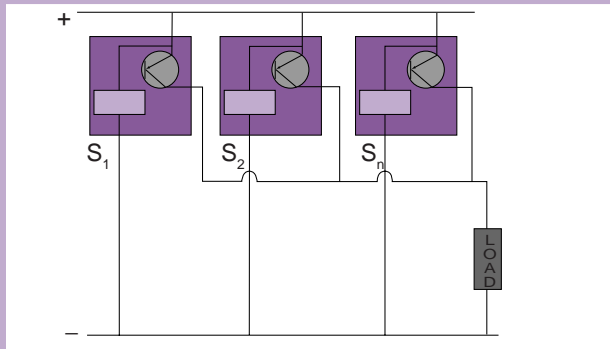

FIGURE 11. Three-wire sensors used in parallel.

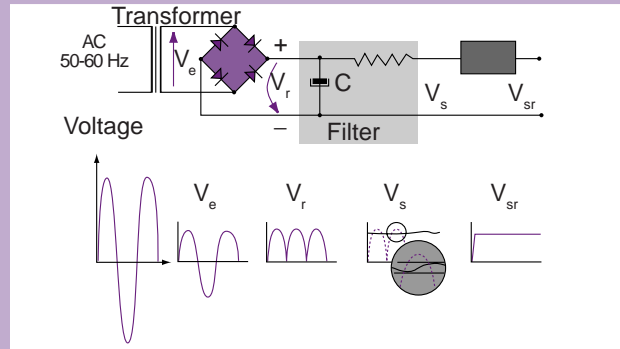

FIGURE 12. Steps involved in converting AC to DC.

capacitor stores energy like a battery. When the current falls, the capacitor discharges and sustains the current flow. The result is an average current, well within the operating range of the sensor. The fluctuation in the curve V_s is called "ripple." The ripple must be within the sensor's power supply range. Note that some sensors are designed to work with unfiltered power supplies. These sensors use built-in smoothing capacitors.

If you have to filter your DC power supply, you can select the correct smoothing capacitor by figuring 400 μF minimum for one switch, or 2000 μF per ampere of load current.

For example, if you have three switches and three 200 mA loads:

$$3 \times 200 \text{ mA} = 600 \text{ mA} = 0.6 \text{ A}$$

$$.6 \text{ A} \times 2000 \mu\text{F} = 1200 \mu\text{F} \text{ for the capacitor}$$

Remember that for three-wire sensors you must also add the sensor's "no load" consumption current which powers their electronics. If you have 20 switches with power supply requirements of 12 mA each, that's a total of 240 mA. The power supply should be dimensioned for at least 0.25 A plus the total load current. \square

CHAPTER 6

Target Speed and Response Time

The factor of timing is inherent in sensors and is measured in milliseconds. If your application is sensing the presence of an auto body on an assembly line, chances are good that you won't have to worry about missing the target because it will be there for a duration of minutes. On the other hand, if you are counting the pins on an electronic component which is travelling by the sensor at 3 feet per second, you are pushing the technology to its limits.

RESPONSE TIME: "INERTIA"

Response time is defined as the duration of time required for the interface to trigger an output. The specifications that indicate a sensor's response time are power-up delay, ON delay and OFF delay.

You can think of response time as "inertia" (the nemesis of perpetual motion inventions).

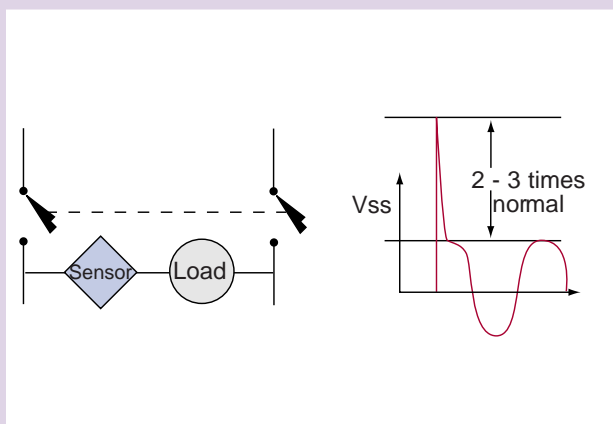

FIGURE 1. Parasitic inductance and capacitance generate transients when a switch closes. The transient passes through the sensor, which falsely signals "ON" to the load..

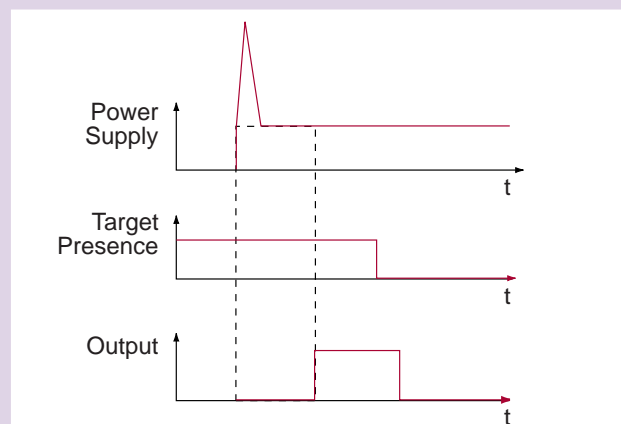

FIGURE 2. Inductive, photoelectric and capacitive proximity switch power-up delays range from 50 ms to 200 ms.

There is no such thing as a perfect sensor - one that responds instantly. In fact, such a sensor would be too sensitive to be practical in industrial environments. Because the sensor interface generates a low-energy signal, the device is extremely susceptible to external transients. Filters are imposed between the trigger and the output circuit to suppress transients. However, filters also affect overall response time performance.

Terms for response time - power-up delay, ON delay and OFF delay - are conservative ratings which the manufacturer guarantees as being the maximum performance for that model of device.

POWER-UP DELAY PROTECTION

Power-up delay* prevents false signals from triggering an ON condition to the load (Figure 1). Parasitic inductance and capacitance builds up in long cables when switches are open; then

when they close they dump a transient spike that can be two or three times the normal voltage. If a power-up delay was not built in, this transient would pass through the sensor switch and signal an ON condition to the load - even if there was no target present in the sensing area. This false signal might cause dire consequences. Because this unsafe condition cannot be tolerated, industry has required that all devices not change state during the power-up phase. The output is intentionally turned off during this period.

You can see in Figure 2 that even when a target is present in the sensing area when power is applied, the output state does not change. For confidence, the delay must last longer than the duration of any start-up transient. Normal power-up delays range from 50 ms to 200 ms for the inductive, photoelectric and capacitive proximity switches.

* Some people call power-up delay "warm-up time." This term is a holdover from vacuum tube technology. Solid-state technology requires no warm-up, so "power-up delay" is a more accurate term.

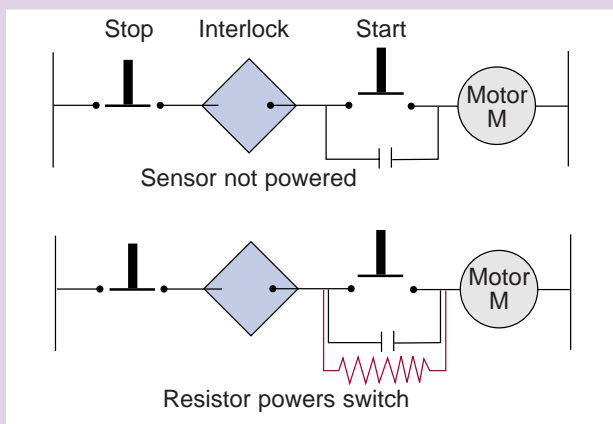

FIGURE 3. Example of electromechanical switches mixed with solid-state switches.

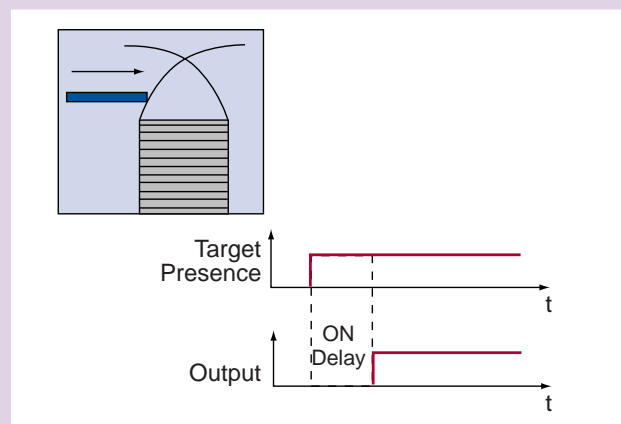

FIGURE 4. ON delay is the time it takes for an output change to be triggered when a target enters the sensing area.

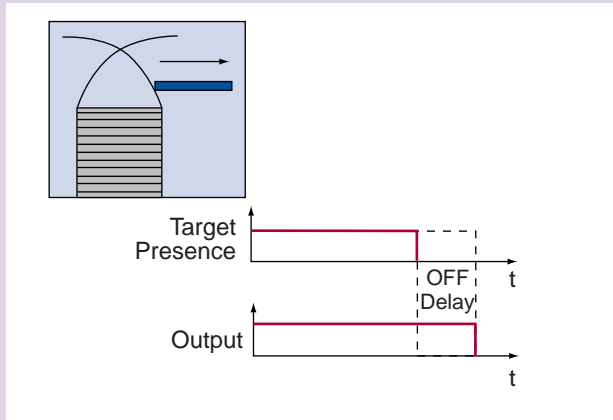

FIGURE 5. OFF delay is the time it takes for an output change to be triggered when a target leaves the sensing area.

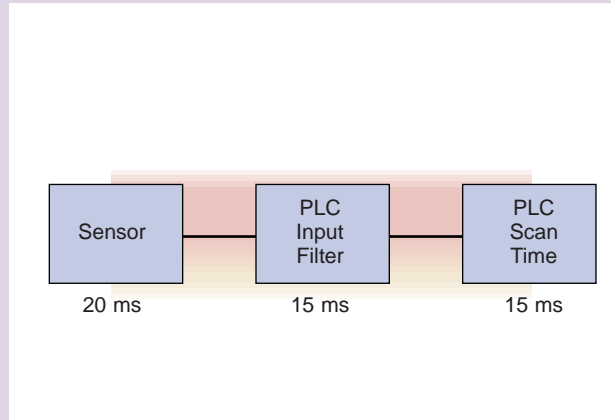

FIGURE 6. Response time includes the entire data acquisition system.

You should avoid using electromechanical switches in series with solid-state sensors if you require a fast response time. When the electromechanical switch is open, no power reaches the solid-state sensor. The solid-state sensor, therefore, has to power-up from a completely inactive state every time the electromechanical contact is closed.

Let's say that your electromechanical switch

is a push button and the sensor serves as an interlock (Figure 3). The button must be held down long enough for the sensor to go through its power-up delay *every time the button is pressed*. It won't sense a target, even if the target is present in the sensing area, until the power-up delay has been completed. The solution for this problem is to wire a resistor with a relatively large value in parallel with the start push button to keep the sensor "warm."

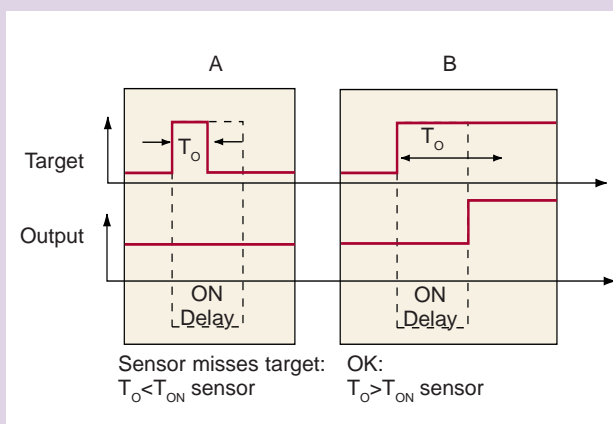

FIGURE 7. Critical response time (ON delay).

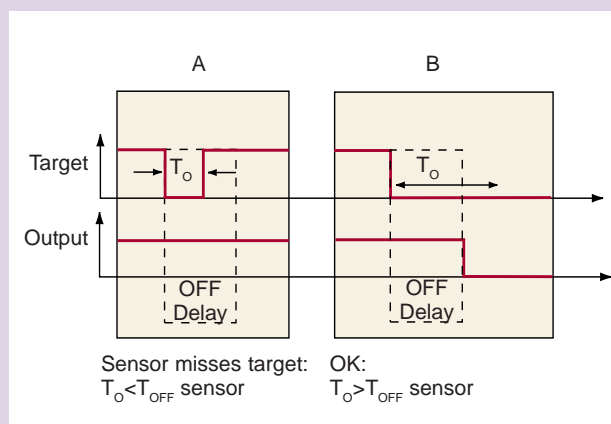

FIGURE 8. Critical response time (OFF delay).

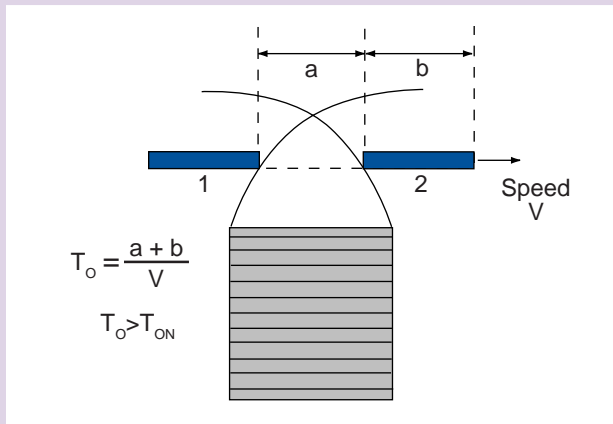

FIGURE 9. Definition of observable time for an inductive sensor.

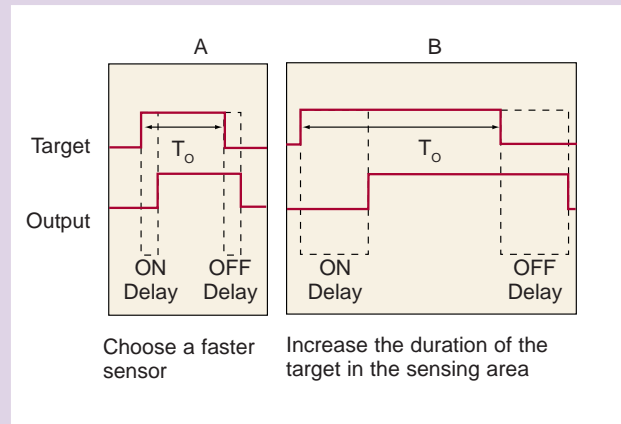

FIGURE 10. Methods to increase observable time.

ON DELAY

Don't confuse ON delay with power-up delay. ON delay is the response time after the unit is powered up. It's the duration of time required for the interface to trigger an output change of state when a target is introduced to the sensing area (Figure 4).

ON delay is usually much faster than power-

up delay. Typical values are 0.1 ms to 5 ms for DC sensors and 5 ms to 10 ms for AC sensors.

OFF DELAY

OFF delay is the amount of time required for the sensor to trigger a change of output state when a target is removed from the sensing area (Figure 5). Typical values are 0.1 ms to 5 ms for DC outputs and 8 ms to 20 ms for AC outputs.

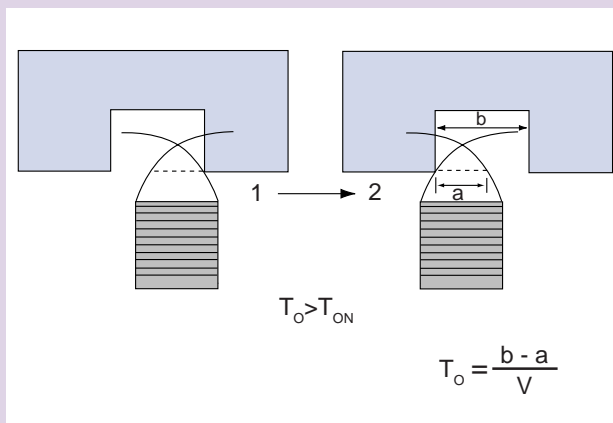

FIGURE 11. Determining observable time for an inductive sensor in a hole or keyway application.

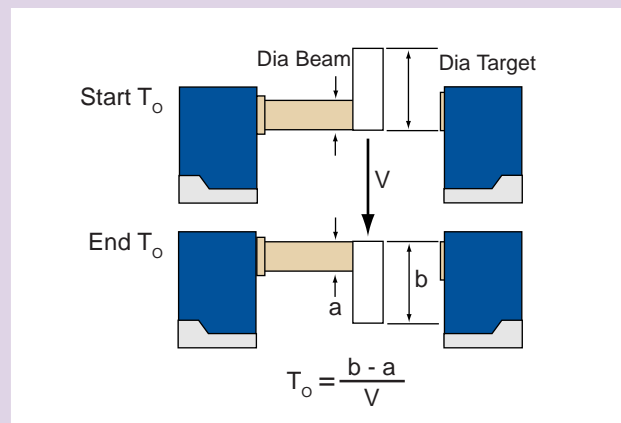

FIGURE 12. Determining observable time for a thru-beam or retroreflective photoelectric sensor.

RESPONSE TIME

We have been discussing the response time of the sensor. However, your application demands that you consider the response time of the entire data acquisition system.

In the model shown in Figure 6, consider that there is a 20 ms ON delay at the sensor, a 15 ms delay at the PLC input module, and the signal must be maintained long enough for the PLC to pick up the change of state in its scan cycle. If the signal does not last long enough, the PLC won't see it during the scan.

During a PLC scan, the PLC reads the status of the inputs, solves the logic programmed, and updates the outputs. The duration of the sensor signal must be longer than the PLC scan time, plus the PLC input filter delay.

The overall system response time is the sum of the ON or OFF delay of the sensor and the PLC input filter, and the PLC scan time.

FILTERS SLOW RESPONSE TIME

Line transients generated in industrial environments need to be suppressed. Filters are effective in doing this so that transients do not trigger false output signals, but filters slow down the output response time.

Larger sensors have larger sensing areas. They have more power to detect, and so have more sensitivity to noise; the more noise, the greater the amount of filtering required. Therefore, large sensors are generally slower than small sensor.

In the real world, there is always a compromise between speed and transient protection. There is also a real-world advantage to using sensors with small sensing areas to detect small or fast moving targets - fast response time.

WHEN DOES RESPONSE TIME BECOME CRITICAL?

Response time becomes critical when you have targets passing the sensor at durations

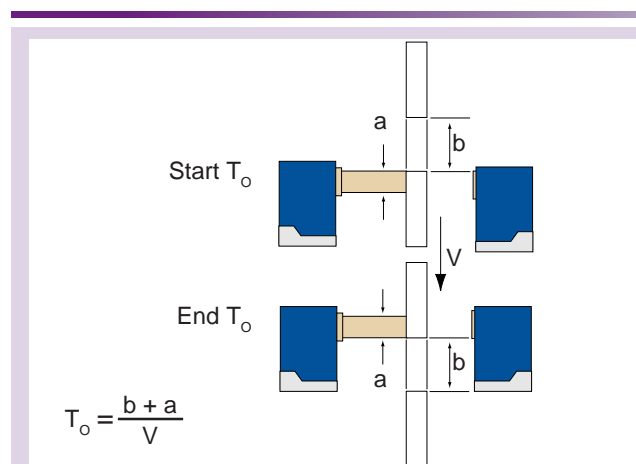

FIGURE 13. Observable time for thru-beam or retroreflective photoelectric sensors used to detect holes.

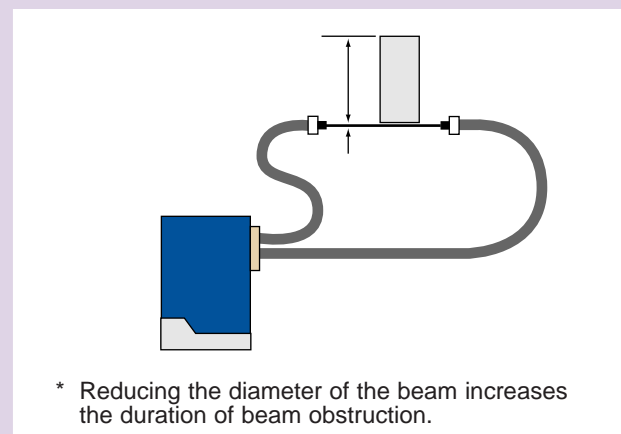

FIGURE 14. Fiber-optic sensors are useful for detecting targets at high speeds.

that are close to either the ON delay or the OFF delay of that sensor. Here's what can happen. If the observable time of the target (T_o) is less than the sensor's ON delay, the sensor will not change states (Figure 7A). If it is longer than the sensor's ON time (Figure 7B), then it is OK.

TARGET LENGTH RELATION

When designing an application, you would like to "arrange" things to be like Figure 7B, which has a decent margin of safety for reliable operation. The observable time should be substantially longer than the sensor's response time. Remember to consider the system's total response time when specifying.

Figure 8 illustrates sensing holes (or the space between targets) instead of targets. In this case, the OFF delay is important. In Figure 8A, a target entered the sensing area before the sensor OFF delay expired, so the output did not change state - it remained ON. In Figure 8B, a target is absent from the sensing area for a time longer than the OFF delay, so the output does change state - to OFF.

Again, you would like to "arrange" things to be like Figure 8B, which has a conservative margin of safety with respect to both the sensor's response time and to the entire system's response time requirements.

OBSERVABLE TIME

Observable time (T_o) is the real time that the target can be observed by the sensor. This represents the time elapsed between position 1 and position 2 in Figure 9. To solve for T_o , you can use the formula:

$$T_o = \frac{a + b}{V}$$

Target observable time (T_o) is equal to the sum of the width of the sensing range (a), plus the width of the target (b), divided by the speed of the target (V). For inductive sensors, when the front of the target passes the ON triggering curve (1), the switch turns ON and will remain ON until the end of the target passes the OFF

curve (2). This represents a length of a+b. Divide it by the speed of the target and the result is the maximum operating time delay, or the total observable time for the target. The observable time of the target should be longer than the sensor reaction time (T_{ON}) in order for the output to change state.

Applying the formula, if the sensing range is 1 inch wide and the target is 1 inch wide and the speed is 2 inches per second, the result is 1 second. ON delay for the switch must be less than 1 second for the target to initiate an output change of state. For practical reasons, usually the "a" term is neglected. If the results are too close for comfort, you have to take the width of the sensing area into consideration. Moving the sensor closer to the target increases "a" and accounts for a longer observable time.

When the observable time of the target is dangerously close to the sensor response time, we need to bring about an increase in target observable time, as well as the time between targets, to levels that give confidence. You'd like to have a *minimum of 2 times T_{ON}* , rather than a fraction over the minimum. How do we do this?

1. As we see in Figure 10A, we can choose a faster sensor. One of the largest improvements in response time occurs when you change from AC to DC output.
2. We can also increase the amount of time that the target is in the sensing area by choosing a sensor or sensor technology that has a smaller sensing pattern in relation to the target (Figure 10B).
3. In the most critical cases, we have to do both.

CALCULATING OBSERVABLE TIME

A keyway in a motor shaft is actually a hole in a metal surface as far as an inductive sensor is concerned. If we have an application where we need to detect the keyway (or holes), we need to analyze how long the sensor will observe the hole (Figure 11).

Between position 1 and 2, the elapsed time is calculated by dividing the length (b-a) by the

Case Study #1

A. Let's say that we have a 30 mm metal target that we want to sense with a 30 mm inductive sensor. T_{ON} for this sensor is 20 ms. If the target is travelling at 1 mm per second, can the target be reliably sensed?

B. Now, let's change the speed to one meter per second. When we plug this into our equation, we get 30 ms for maximum observable time. When we compare this to the response time of the sensor ($T_{ON} = 20$ ms), we

should conclude that this is too close to be reliable since we would like to have a factor of 2 for T_o .

What can we do to improve reliability?

1. Select a DC sensor with $T_{ON} = 2$ ms.
2. Get as close as possible to the surface of the sensor to maximize "a".

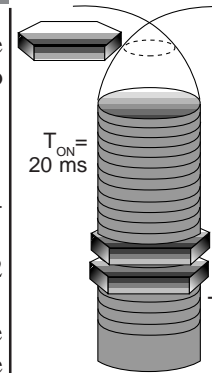

$$T_o = \frac{a + b}{V}$$

30 mm target
30 mm sensor

A. Speed = 1 mm/sec

$$T_o = \frac{30 \text{ mm}}{1 \text{ mm/sec}} = 30 \text{ s}$$

OK

B. Speed = 1000 mm/sec

$$T_o = \frac{30 \text{ mm}}{1000 \text{ mm/sec}} = 30 \text{ ms}$$

Close

Case Study #2

A. In sensing a 30 mm target using an AC photoelectric sensor in thru-beam mode, ON delay is 20 ms and the beam diameter is 10 mm. What is the observable time (T_o) for this application if the target is moving at 1 mm per second?

B. How about if the speed of the target increases to 5 m per second?

We will check the DC version of the standard thru-beam sensor which has ON delay of only 4 ms. This is exactly

T_o , so the tolerance is too small for reliability. If we apply fiber optics, the beam diameter is now only 1 mm. This increases the target observable time by about one third. If we apply a DC fiber-optic sensor, T_o will be 5.8 ms and T_{ON} will be 4 ms.

Success is marginal since we do not have a factor of 2 for T_o . We will recommend that the user slow down a little to 3600 mm/sec (C.), or a sensor with 2 ms or better T_{ON} is chosen.

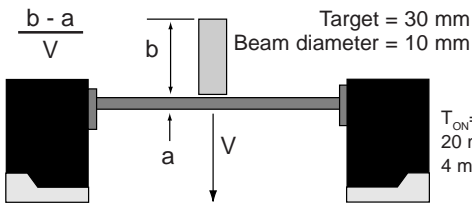

A. Speed 1 = 1 mm/sec $T_o = \frac{30 \text{ mm} - 10 \text{ mm}}{1 \text{ mm/sec}} = 20 \text{ s}$ **OK**

B. Speed 2 = 5 mm/sec $T_o = \frac{30 \text{ mm} - 10 \text{ mm}}{5000 \text{ mm/sec}} = 4 \text{ ms}$ **NO**

C. $T_{Omin} = 2 \times T_{ON} = 8 \text{ ms}$ $V_{max} = \frac{30 \text{ mm} - 1 \text{ mm}}{8 \text{ ms}} = 3600 \text{ mm/s}$ **Better**

Case Study #3

A. Let's push fiber-optic technology to the limit. We will be sensing the 2 mm pin on an electronic component in a counting application. Can we apply a DC fiber-optic sensor in thru-beam mode if the target is moving at 1 mm per second? ($T_{ON} = 4$ ms)

B. How about 1000 mm per second?

C. What we need to do is increase the sensing area, which will also increase the target's observable time. We can do this with fiber optics using proximity diffuse mode. This makes a sensing pattern of 20 mm, which is 20 times larger than the thru-beam mode.

In proximity mode, sensing time starts when light from the target is bounced back to the receiver - it is not based on beam obstruction. Therefore, the target is observable as long as it is in the beam pattern.

Using proximity diffuse mode, we are now able to detect this small, fast-moving target. The observable time of the target is approximately 20 ms, which is well within the specifications of the sensor ($T_{ON} = 4$ ms).

Since the beam pattern is substantially larger than the target, the latter can be neglected in the observable time formula.

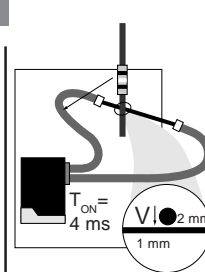

For thru-beam mode: $\frac{b - a}{V}$

Beam diameter = 1 mm
Target = 2 mm

A. Speed = 1 mm/sec

$$T_o = \frac{2 - 1}{1} = 1 \text{ second}$$
 OK

B. Speed = 1000 mm/sec

$$T_o = \frac{2 - 1}{1000} = 1 \text{ ms}$$
 NO

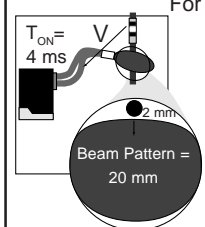

For proximity diffuse mode: $\frac{a + b}{V}$

Beam diameter = 20 mm
Target = 2 mm

C. Speed = 1000 mm/sec

$$T_o = \frac{20 + 2}{1000} = 22 \text{ ms}$$
 OK

speed (V). The observable time of the hole should be longer than the response time T_{OFF} of the sensor in order for the sensor to turn off during the passing hole. In looking at Figure 11, what could we do about this situation - physically - to increase the observable time? Assuming the keyhole width (b) cannot be changed, we could lower the velocity (V), we could reduce the value of (a) by using a smaller sensor, or retract the sensor farther from the target.

Photoelectric sensors use a similar formula for determining the correct response time (Figure 12). It is based on the duration of *total beam obstruction*. Observable time is the difference between the target diameter and the beam diameter, divided by the target speed. One cannot consider ON time to start with partial beam obstruction because of the many variables involved with photoelectric technology (humidity, dusty atmosphere, distance, etc.). Total beam obstruction is the conservative approach for design purposes.

If, for instance, we are close to excess gain 1, very little beam obstruction is needed to turn the switch OFF. On the other hand, if we are functioning at a higher excess gain (perhaps 50), we don't really know how much beam obstruction will actually turn the switch OFF until we try it. Another conclusion is that the larger your target is with respect to beam diameter, the better.

When using photoelectrics to sense holes (Figure 13), the start and stop points for determining T_{O} is again based on total beam obstruction. Therefore, when the first ray is revealed by the hole, this is the starting point. When the last ray is totally obstructed, this is the end point.

For fiber-optic applications (Figure 14), the beam diameter is extremely small. Reducing the diameter of the beam in relation to target size increases the time of beam obstruction. This makes fiber optics an excellent choice for high-speed applications or for small targets. Rule of thumb: your target dimension divided by speed should be greater than the rated ON delay time of your sensor by at least a factor of 2. For all practical purposes, the beam diameter can be neglected as long as it is several

times smaller than the target.

In all cases (inductive, photoelectric, fiber optic), if the target (plain or hole) is substantially larger than the sensor's sensing area, you can neglect the sensor's sensing pattern characteristics and concentrate on the target. This makes life easier because when you can neglect the "a" term in the formula, you can forget about the "+" or "-" signs.

Three case studies of typical applications are presented. □

CHAPTER 7

Standard Operating Frequency

What is standard operating frequency, and what is it good for? The standard operating frequency specification gives you a general idea of how fast the sensor reacts. Because it is a standardized parameter, you can compare the products of various manufacturers using this figure, so you can be sure you are comparing “apples to apples.” You can also use it as a guide for choosing sensor series or types from a single manufacturer. For instance, smaller sensors and DC sensors typically are faster than larger sensors and AC sensors, respectively.

The maximum operating frequency is an industry standard just like the nominal sensing distance. The method of arriving at this parameter is to place standard targets on a

rotating disk. The targets are spaced on the disk in a well-defined geometrical configuration (Figure 1).

For inductive, capacitive and magnetic technology, the sensor is mounted perpendicular to the shaft at a distance of one half its nominal sensing distance from the target as illustrated in Figure 1. Photoelectric and ultrasonic sensors are mounted parallel to the shaft facing the targets. The disk is rotated and the output of the sensor is displayed on an oscilloscope. (Photoelectric sensors need an additional fast sensor to precisely trigger the oscilloscope.) The speed of the disk is increased until reaching a point where detection practically stops. The frequency of targets passing the sensor at this point is the maximum operating frequency.

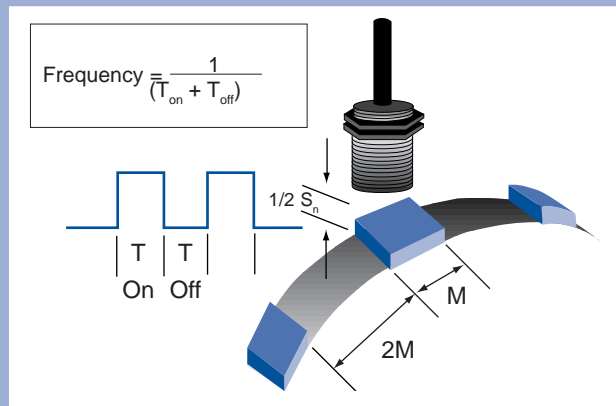

FIGURE 1. Standard operating frequency setup.

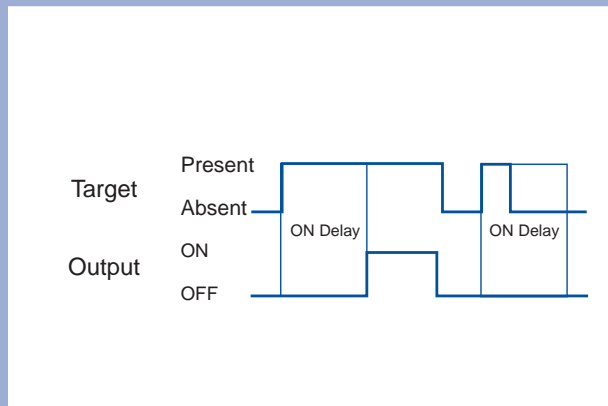

FIGURE 2. ON delay.

Caution: Operating frequency is a useful selection guide, but do not use it to solve your application problems. Operating frequency relates to a standard target in a standardized laboratory setup. Always use actual sensor response time(s) — ON/OFF delay — to analyze your application.

USING TIMING FUNCTIONS

Up to now we have analyzed the application to see if the sensor can detect progressively faster and smaller targets. Now we are going to talk about adjusting the response times to solve some common applications. We will introduce an adjustable time delay between the trigger and output circuits in the sensor. You have three basic tools for this:

1. ON delay which is used to prolong the OFF condition after the target is detected.
2. OFF delay which is used to prolong the ON-condition after the target is no longer detected.
3. Monostable (one shot or pulse stretcher) which is used to provide a measured ON time “window” regardless of the presence of the target. It can be triggered either by target or non-target detection.

Note: Once any of these types of time delays has been triggered, the output is controlled by the timer regardless of the presence or absence of the target.

ON DELAY

Figure 2 shows a target that comes into the sensing area for a long period of time, maybe 10 seconds. We have adjusted the ON delay for 5 seconds, so the target is present in the sensing area for 5 seconds before the output is energized. When the target leaves the sensing area, the output changes states without delay. When a target comes into the sensing area for only 2 seconds, it is neglected. The timer keeps the output ON for all its set 5 seconds.

Example: A car pulls into a drive-thru bank teller. A thru-beam photoelectric sensor detects the presence of the car and an alarm sounds to call the bank teller to the window. What if a leaf momentarily blocks the beam? Or a dog runs by (Figure 3)? These things could cause the system to be a nuisance. Controlling ON delay lets you detect targets that enter the sensing area and stay there longer than a preset time (e.g., 5 seconds), thus reducing or eliminating nuisance trips.

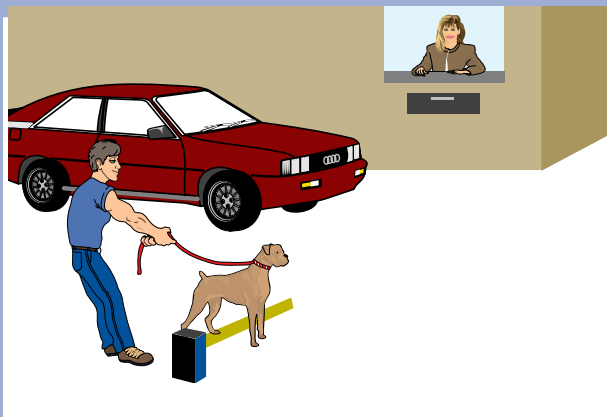

FIGURE 3. Cars are detected; interference is neglected.

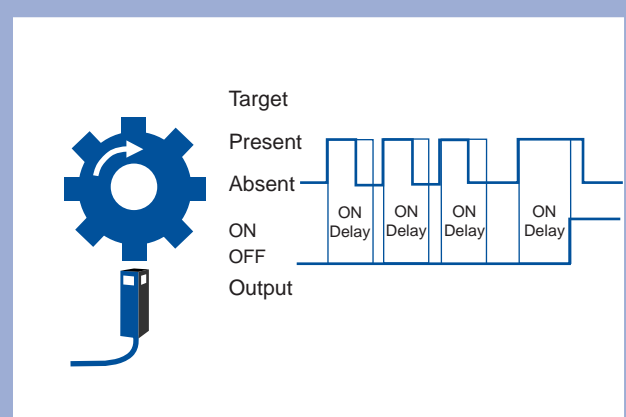

FIGURE 4. ON delay for underspeed detection.

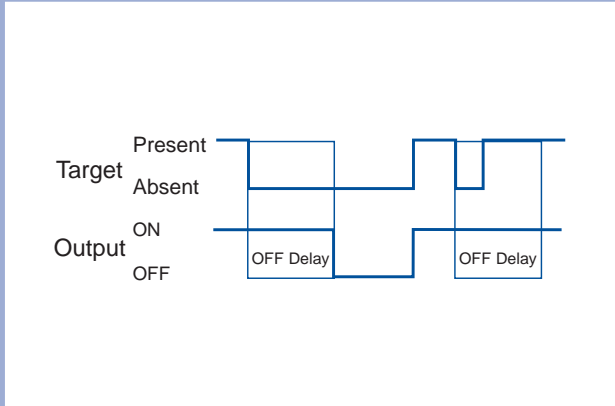

FIGURE 5. OFF delay.

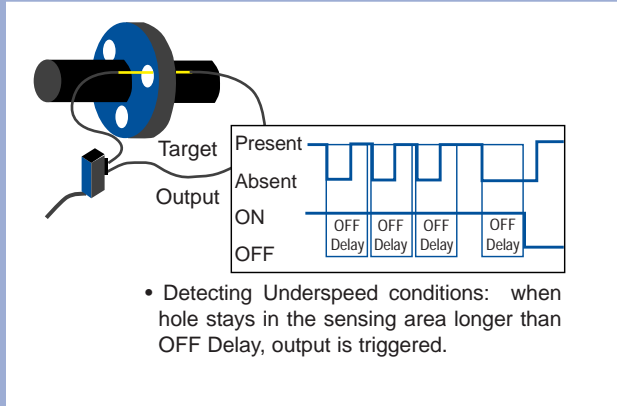

FIGURE 6. A thru-beam fiber-optic sensor detecting an underspeed condition with OFF-delay.

Example: A thru-beam photoelectric system is set up for detecting the level of fluid in a vat which has transparent walls. As fluid is added, the surface ripples. Ideally, the photoelectric sensor system would like a calm (no ripples) surface to detect. Because ripples break the beam, the sensor output will rapidly turn ON and OFF. This “chattering” effect can quickly damage a solenoid valve or contactor used to control the liquid level. You can use ON delay to neglect signals caused by the waves and change output states only after a couple of seconds pass without ripple. This is recommended when the normal hysteresis of the target cannot cope with the physical variations of the target. A HI-LO type of control would work smoothly using the ON delay feature.

Example: You can use ON delay to detect underspeed conditions. This is important in many systems where an improper condition, such as a jam or a mechanical malfunction, is causing a motor to slow down, and therefore causing it to heat up. Before that motor heats up to the point where its own thermal protection saves it, but makes you wait many precious minutes before you can restart, you’d like to know that you’ve got a problem you can manage with minimum downtime. You set the sensor ON delay such that it extends the output OFF condition until just before the next target enters the sensing area (Figure 4). The sensor stays OFF-at normal speed. When the target stays in the sensing area longer than the ON delay, the output will change states, signaling the underspeed condition.

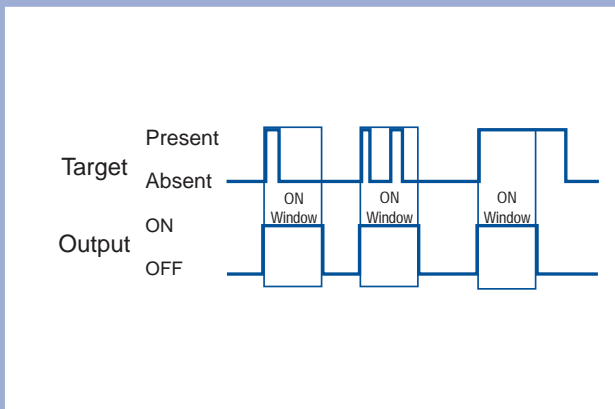

FIGURE 7. One shot or pulse stretcher.

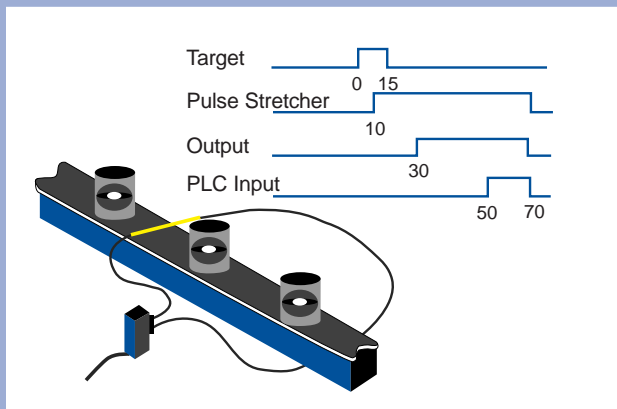

FIGURE 8. A thru-beam fiber-optic sensor detecting misplaced labels with a pulse stretcher.

OFF DELAY

OFF delay is basically a mirror image of ON delay (Figure 5). Just as ON delay prolongs the OFF-condition, OFF delay prolongs the ON condition. The idea with OFF-delay is to detect an irregularity in the rate of holes (spaces) between targets.

You can apply OFF delay in the same way you used ON delay — i.e., to detect underspeed and to eliminate “noise.” One of the main reasons you use OFF-delay is when spaces are easier to detect than targets.

Example: Cans of product are spaced evenly on a conveyor system. An inductive sensor is installed to detect the spaces between the cans. Using OFF-delay, the output state remains ON as long as the metal cans keep entering the sensing area at regular intervals. If a can is on its side, a space that is longer than the OFF-delay will trigger an output change of state.

Example: Instead of detecting gear teeth using ON delay, we are now detecting holes in a flywheel using OFF delay (Figure 6). As long as the holes pass in a time less than the OFF delay, the sensor does not change its ON output state. When the hole is in the sensing area longer than the set OFF delay, the output is triggered.

ONE SHOT OR PULSE STRETCHER (MONOSTABLE OUTPUT)

A monostable sensor is commonly called a “one shot” timer or “pulse stretcher.” You preset a window of time that you want the output to remain ON. Once the target is sensed, the internal timer takes over, so that the output stays ON, irrespective of the target status. It’s called “one shot” because it turns ON only one time per target. It takes another target to trigger another “shot.”

Figure 7 shows a one shot that is triggered when energized (from absent to present). It stays ON for its preset duration and does not come ON again until the next time the sensor interface changes states from absent to present. Notice that if a transition from absent to present happens within the ON time window, it is neglected.

It is important to note that the one shot pulse can also be triggered by the present to absent transition. This is a choice in logic that

you can usually preset. You must choose one transition mode or the other, according to the needs of your application (ON or OFF delay).

The pulse stretcher is useful if you have a slow system response time and a short target observable time. The event might be too fast for the system to respond. That’s when you want to use the ON “window” functions as a pulse stretcher — it lets you “stretch” the signal duration of a fast event to one that will be “seen” by the system.

Example: In detecting misplaced labels on canned food, a thru-beam fiber-optic sensor is set for just above the height of the can (Figure 8). If the label is misapplied, a corner will stick up higher than the can and block the beam. This is an extremely fast event. The beam is broken for only 15 milliseconds. The sensor’s ON delay is 30ms. The programmable logic controller (PLC) processing this information needs about 40ms to account for a 20ms ON delay for the input filter and a 20ms scan time. The sensor internal monostable circuit can react in less than 10ms. If the “one shot” time is preset to 60ms, the PLC can properly record the event. From the PLC perspective it is like the target has been in front of the sensor for the entire 70ms time period. □

Square D
8001 Hwy 64 East
Knightdale, NC 27545 USA
(919) 266-3671

Square D and  are registered trademarks of Square D.

Electrical equipment should be serviced only by qualified electrical maintenance personnel. No responsibility is assumed by Square D for any consequences arising out of the use of this material.

